

NOTĂ:

- Cota +0.00 m corespunde cu nivelul superior al pardoselii finite a parterului;
- Terenul de fundare este constituit din nisipuri fine prăfoase la argiloase, cafenii galbuli, cu indesare medie, compresibilitate medie, umede;
- Presiunea convențională de baza este  $P_c=174kPa$ ; pentru lățimea fundatiei  $B=60cm$  și adâncimea de fundare  $h_f=80cm$ ;
- Umpluturile de pământ vor fi compactate în straturi de maxim 15cm cu aducerea fiecărui strat la umiditatea optimă de compactare;
- În situația în care la cota de fundare vor fi întâlnite umpluturi neconsolidate sau terenuri stabe se va anunța proiectantul;
- Dacă la executarea săpăturilor se vor găsi cabli electrice, conducte de apă, canal se va anunța proiectantul.

Beton C16/20 (B25) cu impermeabilizare  $P_0$  - fundatii  
 Otel beton BST500S / OB37; STNB  
 Sarmă de legat, STAS 895-80  
 Accierire  $a=5cm$  (fundatii)

Pentru turnare pe timp calduros se va folosi aditiv intarziator de priză superplasticizant.  
 Pentru turnare pe timp friguros (sub  $5°C$ ) se va folosi aditiv anti-îngheț și accelerat de priză.

NOTA:  
 CONFORM HG766/1997, CONSTRUCTIA SE INCADREAZA IN CATEGORIA DE IMPORTANTA "C".  
 CONFORM P100-1/2019, ZONA SEISMICA ESTE CARACTERIZATA DE  $a_g = 0.15g$ ,  $T_c = 0.7$  sec.

VERIFICATOR/Expert:		Nume	Semnatura	Cerinta	Referat / Superizo nr./data
EXPERT TEHNIC:		Ing. Jeff PLOIA	[Signature]	A1, A2, A3	1188
BENEFICIAR:		U.A.T. PRUNISOR			
PROIECTANT:		UP-Architecture s.r.l.			
DESENAT:		Ing. Jeff PLOIA			
SCALA:		1/50			
DATA:		01/2025			
TITLU PAGINA:		PLAN FUNDATII			
PROIECT NUMAR:		70.24/UPA			
Faza:		D.T.A.C.-P.T.			
Plansa numar:		R-01			

SECTIUNEA 1-1

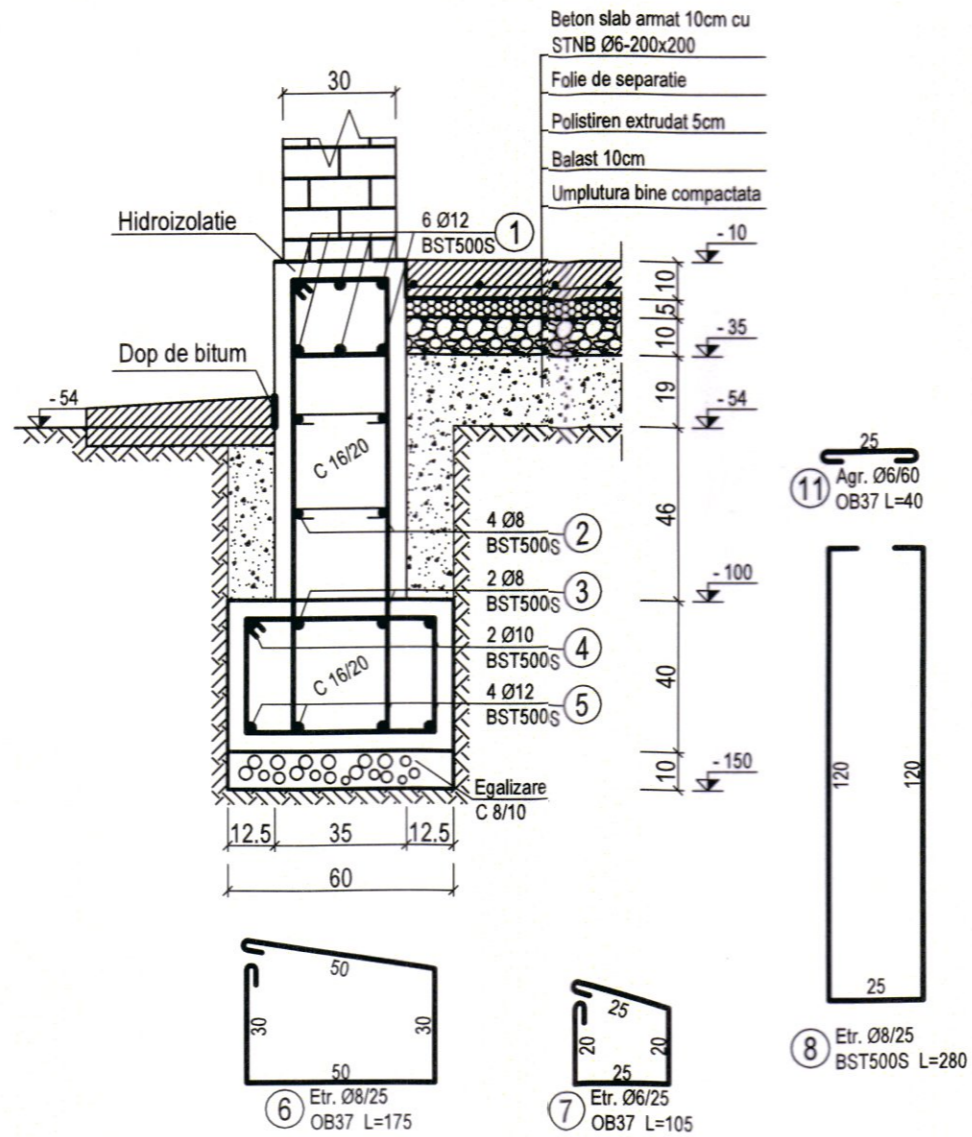

SECTIUNEA 2-2

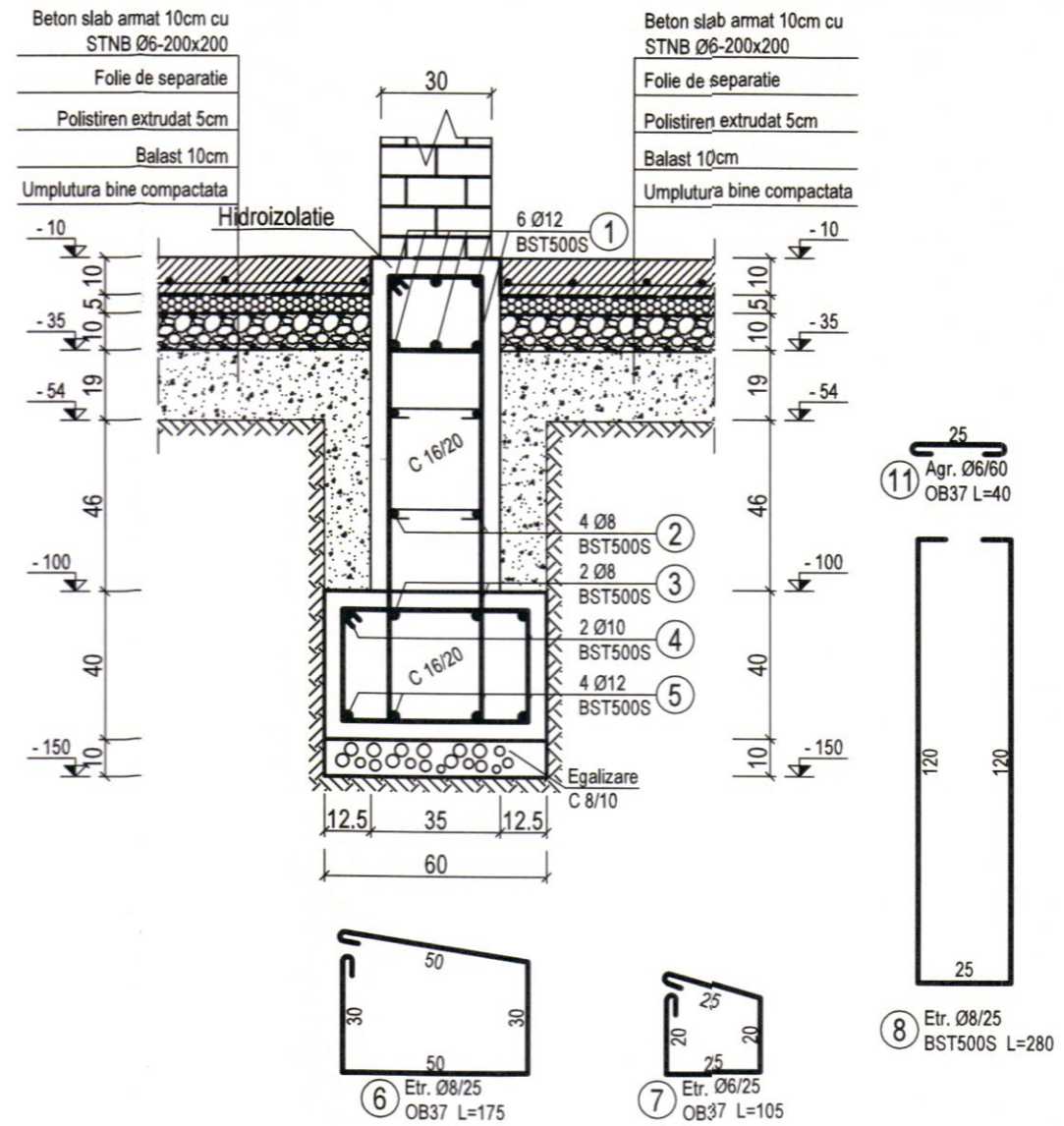

Beton C16/20 (B250) cu impermeabilizare P<sub>10</sub> - fundatii  
 Otel beton BST500S / OB37; STNB  
 Sarma de legat, STAS 889-80  
 Acoperire a=5 cm (fundatii)

Pentru turnare pe timp calduros se va folosi aditiv intarziator de priza+superplastifiant.  
 Pentru turnare pe timp friguros (sub 5°C) se va folosi aditiv anti-inghet si accelerator de priza.

Beton	C 8/10 - B 150 C 16/20 - B 250
Otel	OB 37 BST500S

NERESPPECTAREA INTOCMAI A PROIECTULUI, DE CATRE BENEFICIAR SAU CONSTRUCTOR, ABSOLVA PROIECTANTUL DE ORICE RASPUNDERE.

Vericatori/Experti:	Nume	Semnatura	Cerinta	Referat	Expertiza
VERIFICATOR:			A1, A2, A3		
EXPERT TEHNIC:					

s.c. URBAN PLANNING ARCHITECTURE s.r.l. C.U.I. 39884638 J25/466/18.09.2018 E-mail: uparchitecture@yahoo.com		BENEFICIAR:	U.A.T. PRUNISOR	Proiect numar: 70.24/UPA
UP-Architecture				
Señ proiect	arh. Sorin Puiu BARLAN	SEMNTATURA	SC:	OBIECTIV: Demolare cladire existenta C1 si Construire gradinita doua grupe
Proiectat	ing. Jeff PLOIA		1/20	AMPLASAMENT: nr. cad. 51367, comuna Prunisor, sat Prunisor, jud. Mehedinti
Desenat	ing. Jeff PLOIA		DATA: 01/2025	TITLU PAGINA: DETALII FUNDATII
				Faza: D.T.A.C.-P.T.
				Plansa numar: R-02

SECTIUNEA 3-3

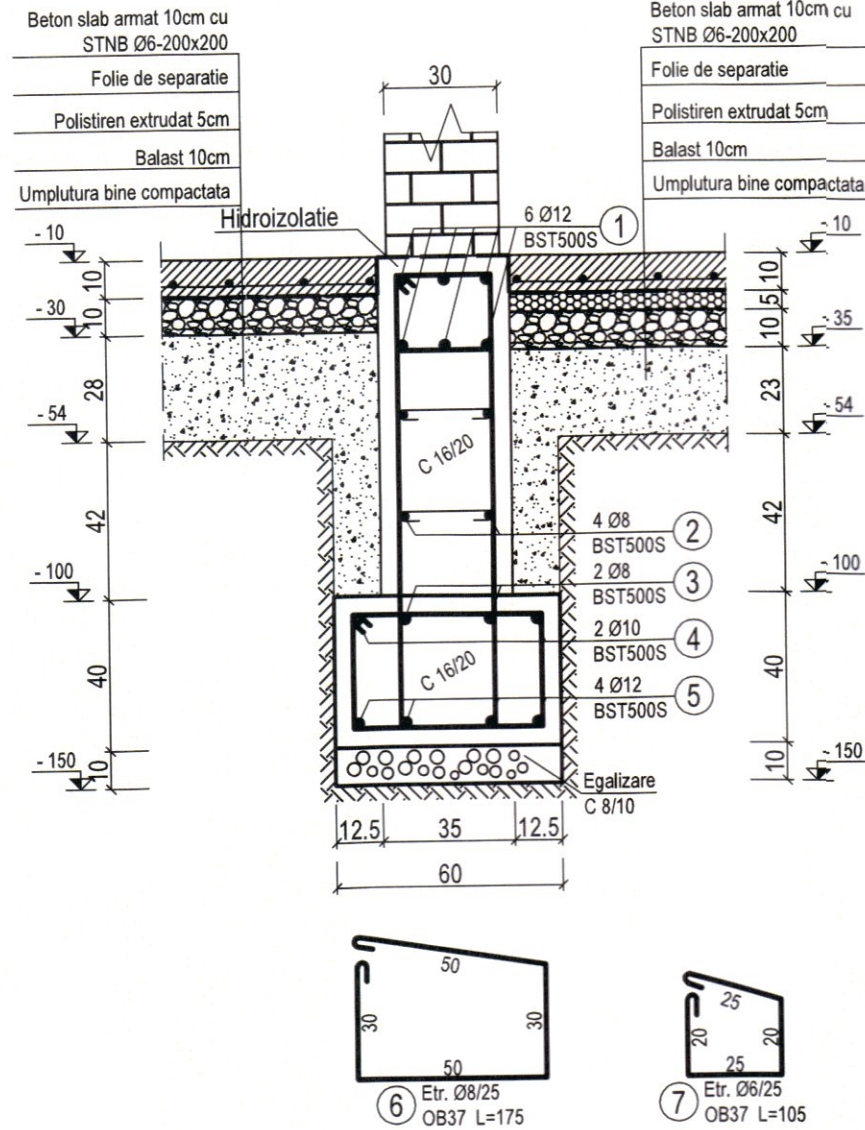

SECTIUNEA 4-4

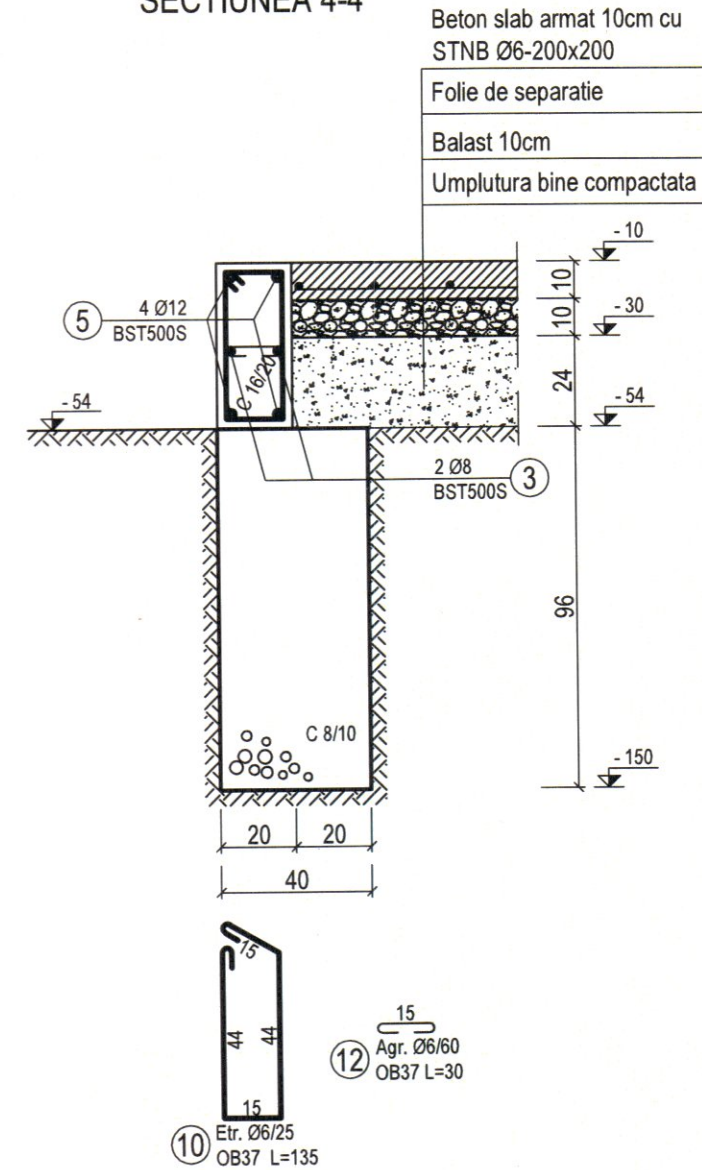

Beton	C 8/10 - B 150
	C 16/20 - B 250
Otel	OB 37
	BST500S

Beton C16/20 (B250) cu impermeabilizare P<sub>8</sub><sup>10</sup> - fundatii  
 Otel beton BST500S / OB37; STNB  
 Sarna de legat, STAS 889-80  
 Acoperire a=5 cm (fundatii)

Pentru turnare pe timp calduros se va folosi aditiv intarziator de priza+superplastifiant.  
 Pentru turnare pe timp friguros (sub 5°C) se va folosi aditiv anti-inghet si accelerator de priza.

NOTA:

CONFORM HG766/1997, CONSTRUCTIA SE INCADREAZA IN CATEGORIA DE IMPORTANTA "C".  
 CONFORM P100-1/2019, ZONA SEISMICA ESTE CARACTERIZATA DE ag = 0.15g , Tc = 0.7 sec.

NERESPECTAREA INTOCMAI A PROIECTULUI, DE CATRE BENEFICIAR SAU CONSTRUCTOR, ABSOLVA PROIECTANTUL DE ORICE RASPUNDERE.

Verificatori/Experti:	Nume	Semnatura	Cerinta	Referat / Expertiza nr./data
VERIFICATOR:			A1, A2, A3	
EXPERT TEHNIC:				
<b>UP-Architecture</b> s.c. URBAN PLANNING ARCHITECTURE s.r.l. C.U.I. 2084338 J25/466/18.09.2018 E-mail: uparchitecture@yahoo.com				BENEFICIAR: <b>U.A.T. PRUNISOR</b>
Proiectat	ing. Jeff PLOIA	SEMNTURA	SC: 1/20	OBIECTIV: Demolare cladire existenta C1 si Construire gradinita doua grupe AMPLASAMENT: nr. cad. 51367, comuna Prunisor, sat Prunisor, jud. Mehedinti
Desenat	ing. Jeff PLOIA		DATA: 01/2025	Faza: D.T.A.C.-P.T. Titlu pagina: DETALII FUNDATII
				Proiect numar: 70.24/UPA Planşa numar: R-03







S5 - 30x60 - 2buc

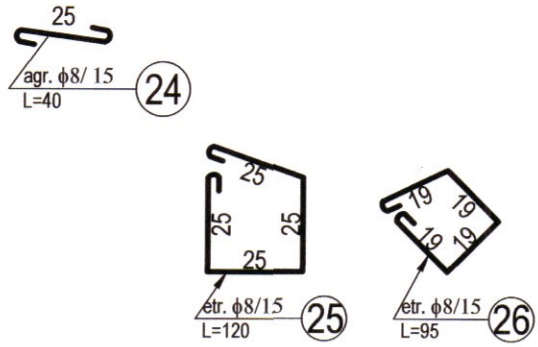
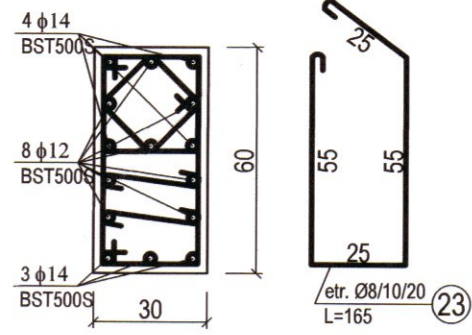

S7 - 30x130x100 - 1buc

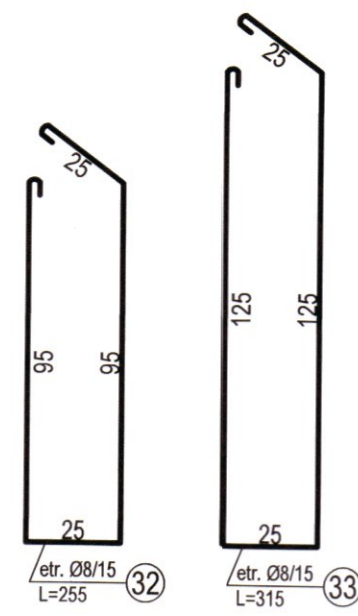
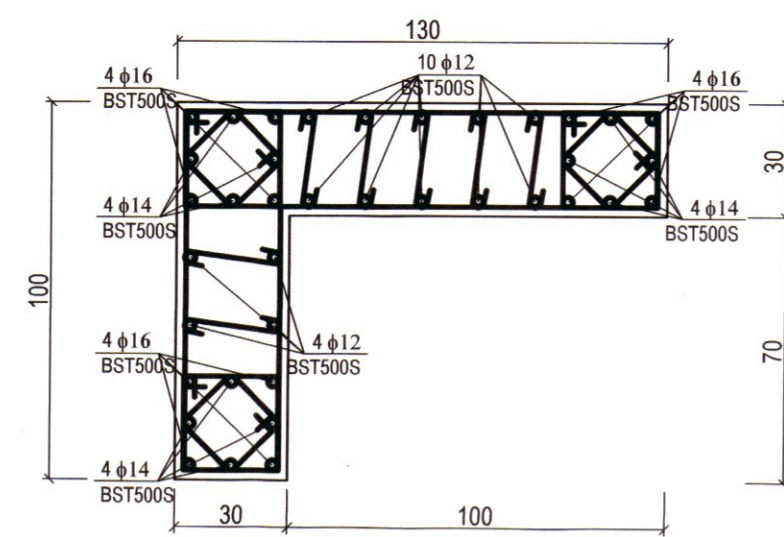

S12 - 30x75 - 2buc

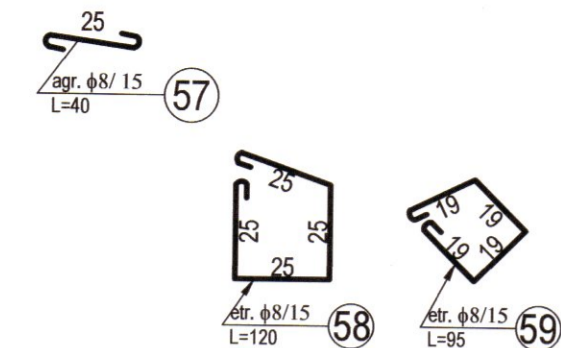
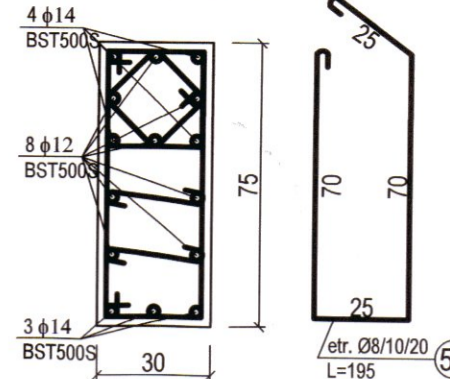

S1 30x30 - 12buc

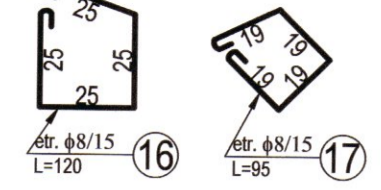
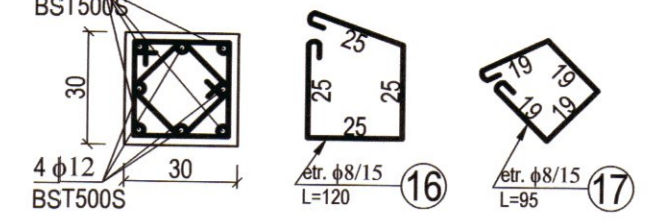

S6 - 30x80x100 - 1buc

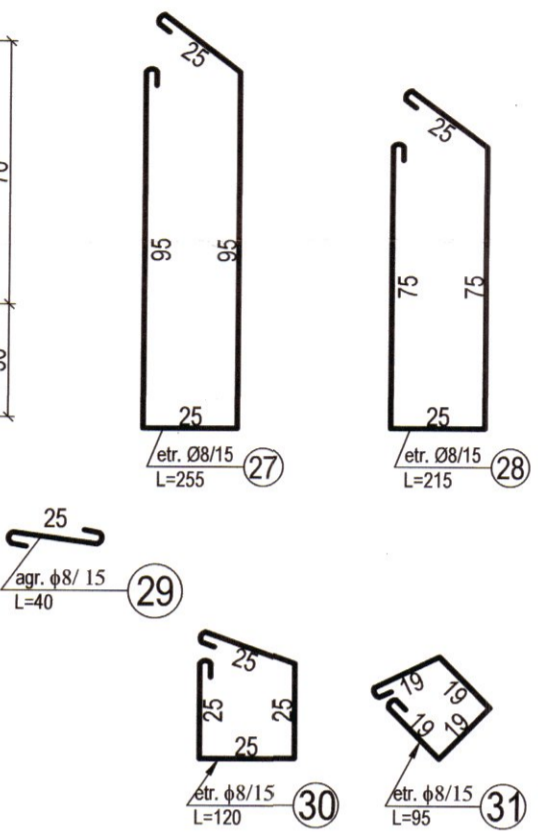
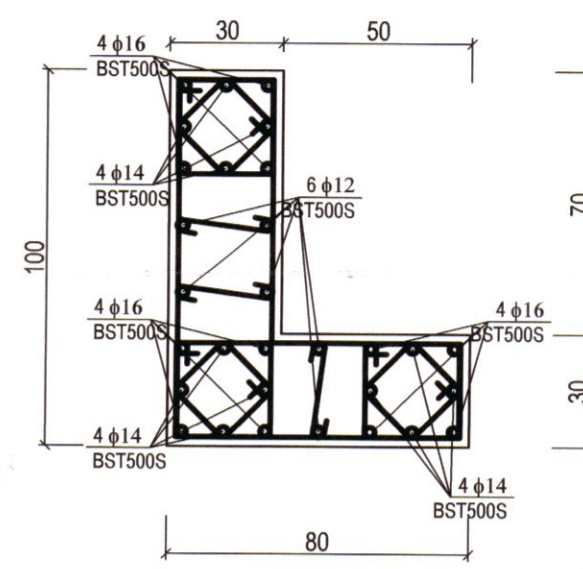

S8 - 30x70x100 - 2buc

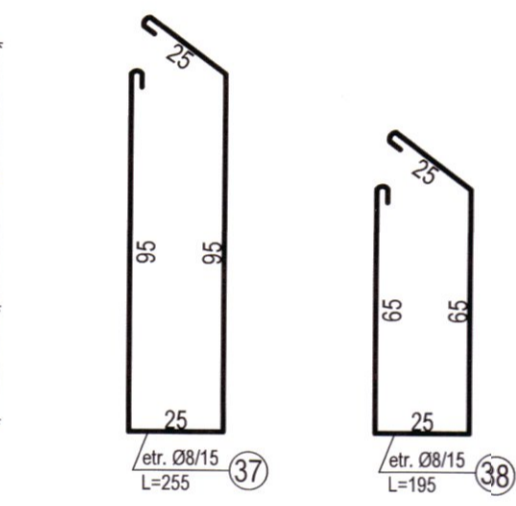
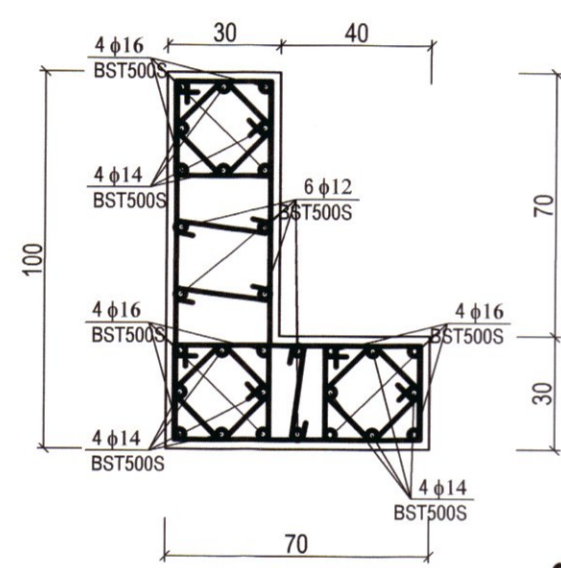

S10 - 30x90 - 1buc

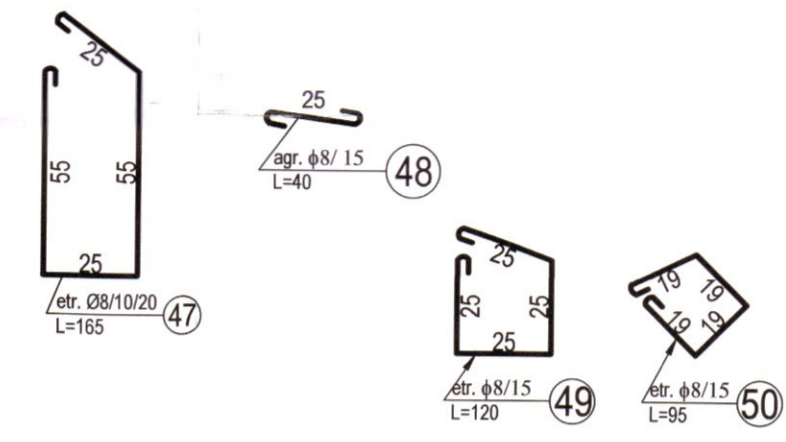
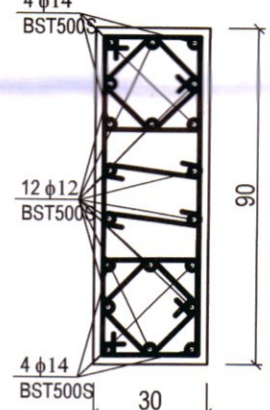

S2 - 30x100 - 6buc

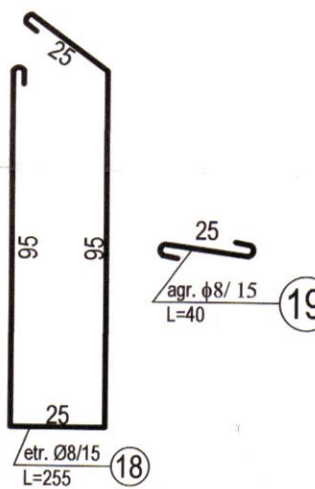
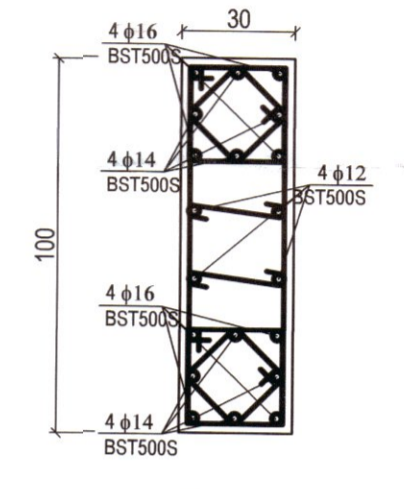

DETALII ARMARE STALPI

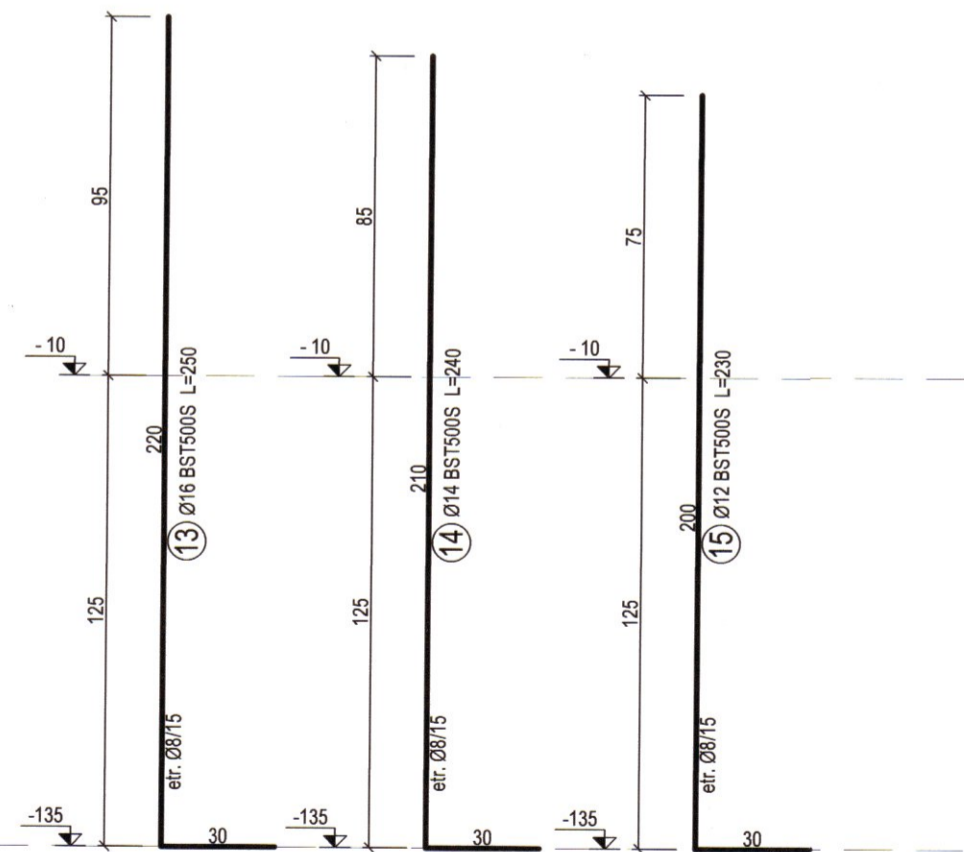

S9 - 30x50x80 - 1buc

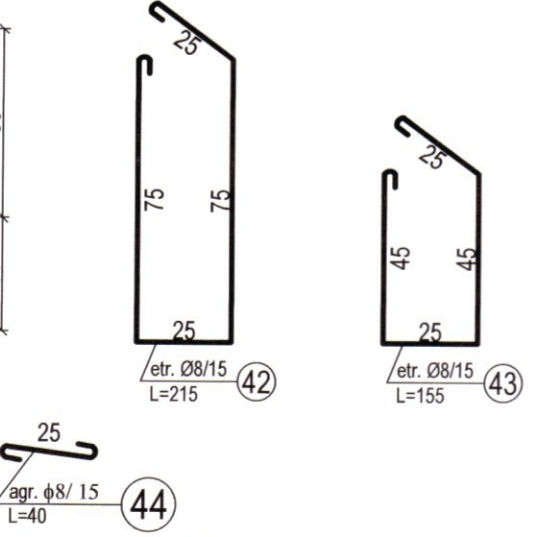
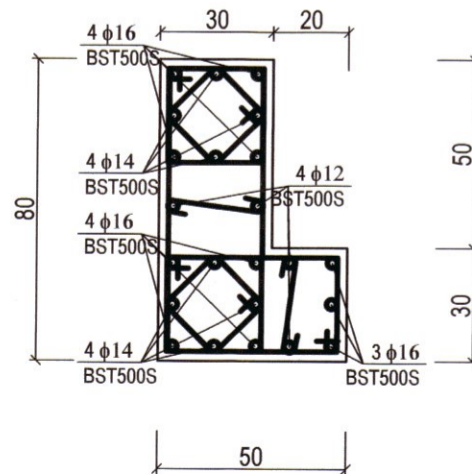

S11 - 30x60x100 - 1buc

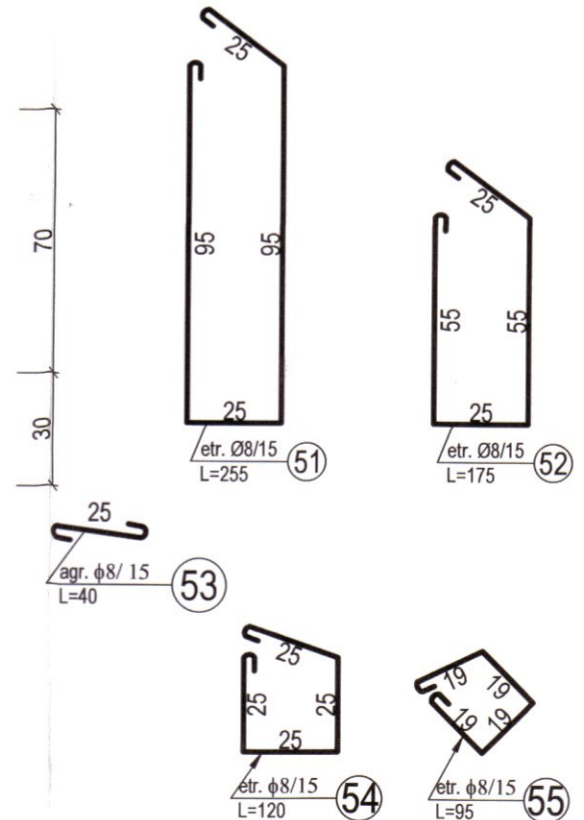
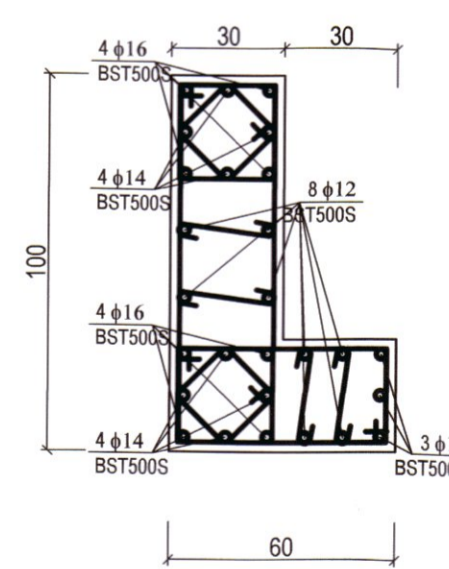

S3 - 30x55 - 7buc

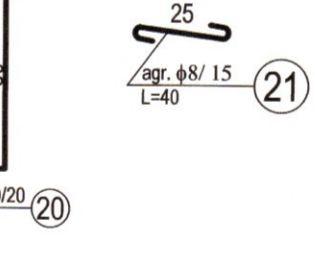
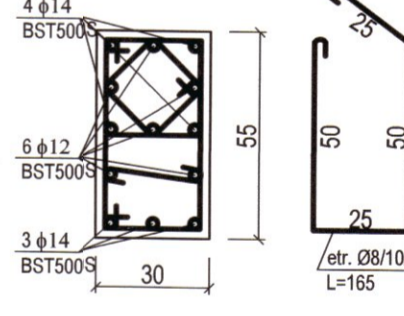

S4 - 30x50x50 - 2buc

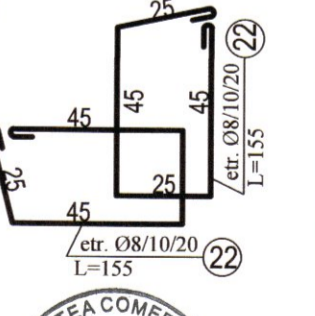
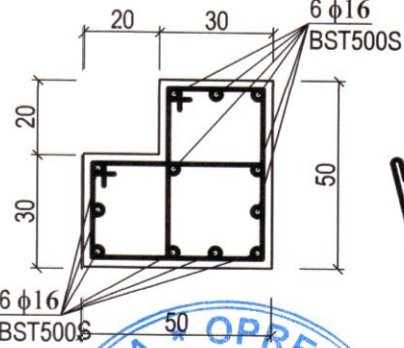

Beton C16/20 (B250) cu impermeabilizare P<sub>8</sub><sup>10</sup> - fundatii  
 Otel beton BST500S / OB37; STNB  
 Sarma de legat, STAS 889-80  
 Acoperire a=5 cm (fundatii)

Beton C 8/10 - B 150  
 C 16/20 - B 250  
 Otel OB 37  
 BST500S

Pentru turnare pe timp calduros se va folosi aditiv intarziator de priza-superplastifiant.  
 Pentru turnare pe timp friguros (sub 5°C) se va folosi aditiv anti-inghet si accelerator de priza.

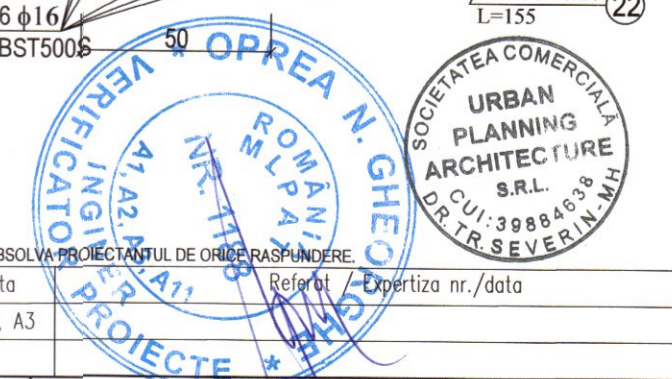

NERESPETAAREA INTOCMII A PROIECTULUI DE CATRE BENEFICIAR SAU CONSTRUCTOR. ABSOLVA PROIECTANTUL DE OBLIGATII DE RASPUNDERE.			
Verificatori/Experti:	Nume	Semnatura	Cerinta
VERIFICATOR:			A1, A2, A3
EXPERT TEHNIC:			Referat / Expertiza nr./data
<b>UP-Architecture</b>		BENEFICIAR:	
s.c. URBAN PLANNING ARCHITECTURE s.r.l. C.U.I. 39884638 J25466/18.09.2018 E-mail: uparchitecture@yahoo.com		<b>U.A.T. PRUNISOR</b>	
SC:	1/20	OBIECTIV:	Demolare cladire existenta C1 si Construire gradinita doua grupe
Proj. arh.:	ing. Sorin Puiu BARLAN	AMPLASAMENT:	nr. cad. 51367, comuna Prunisor, sat Prunisor, jud. Mehedinti
Proj. ing.:	ing. Jeff PLOIA	DATA:	01/2025
Desenat:	ing. Jeff PLOIA	TITLU PAGINA:	DETALII FUNDATII
		Proiect numar:	70.24/UPA
		Faza:	D.T.A.C.-P.T.
		Plansa numar:	R-06

DETALII FUNDATIE F1 - 1 buc.  
Sectiunea 1-1

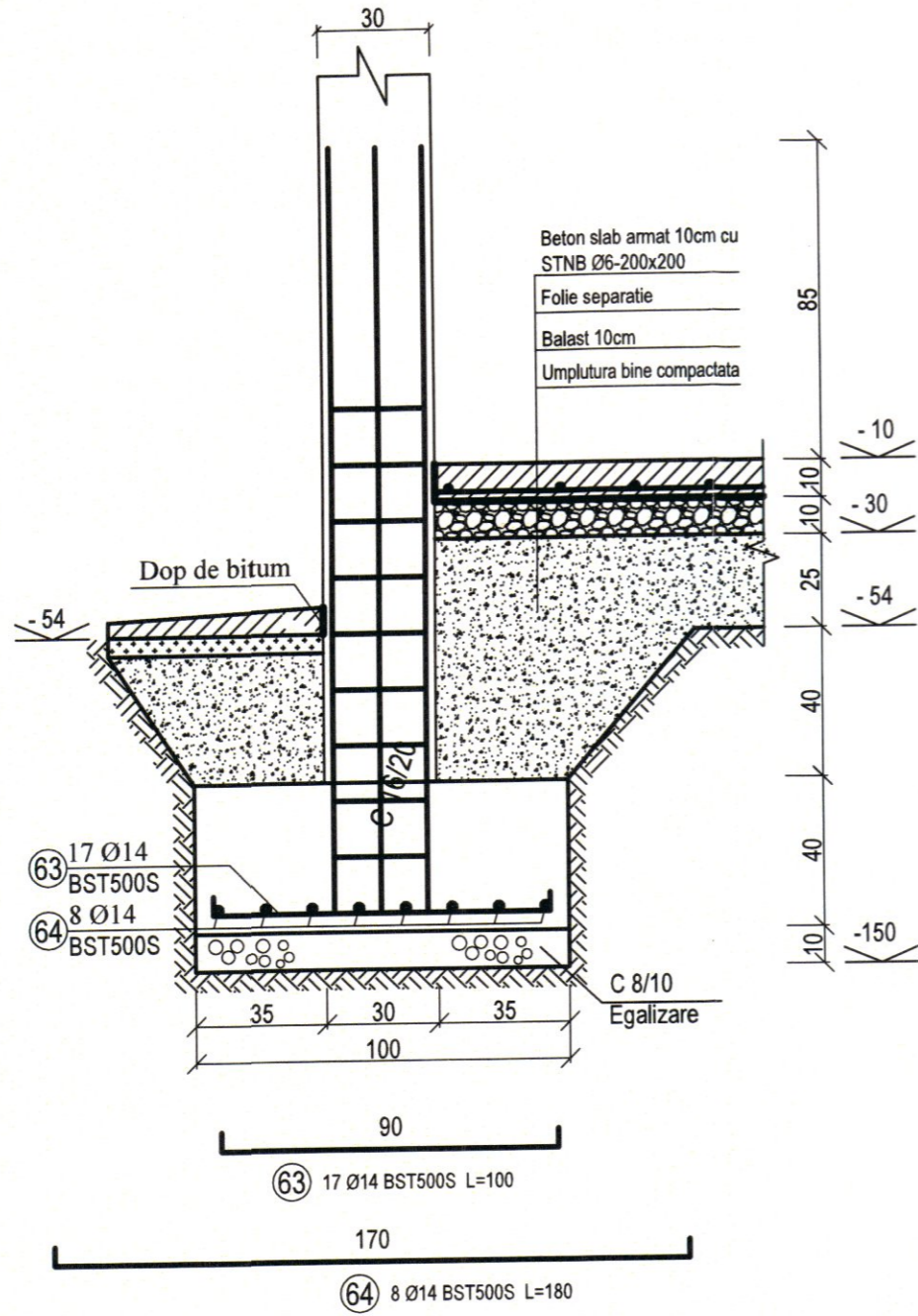

Beton C16/20 (B250) cu impermeabilizare P<sub>8</sub><sup>10</sup> - fundatii  
Otel beton BST500S / OB37; STNB  
Sarma de legat, STAS 889-80  
Acoperire a=5 cm (fundatii)

Pentru turnare pe timp calduros se va folosi aditiv intarziator de priza+superplastifiant.  
Pentru turnare pe timp friguros (sub 5°C) se va folosi aditiv anti-inghet si accelerator de priza.

Beton	C 8/10 - B 150 C 16/20 - B 250
Otel	OB 37 BST500S

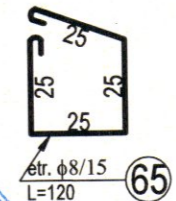
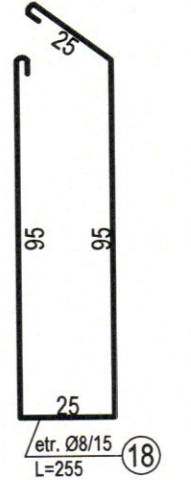
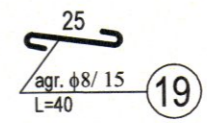
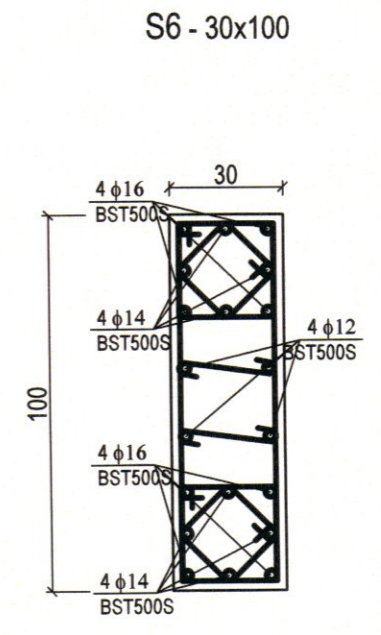
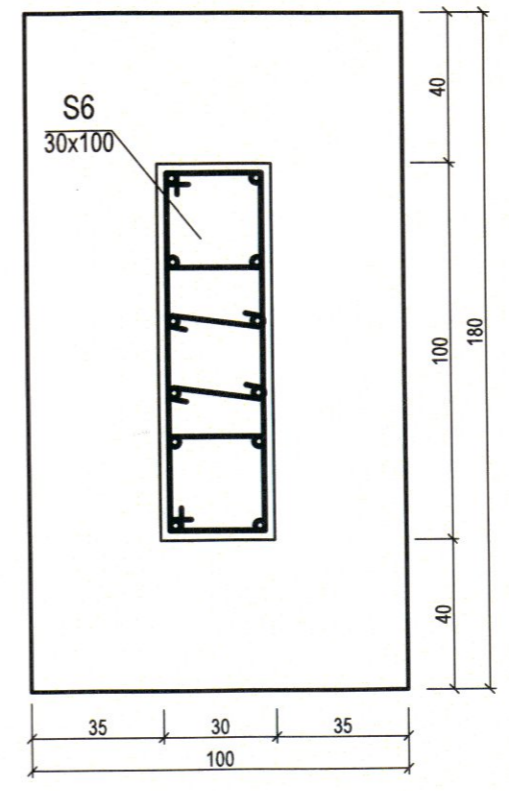
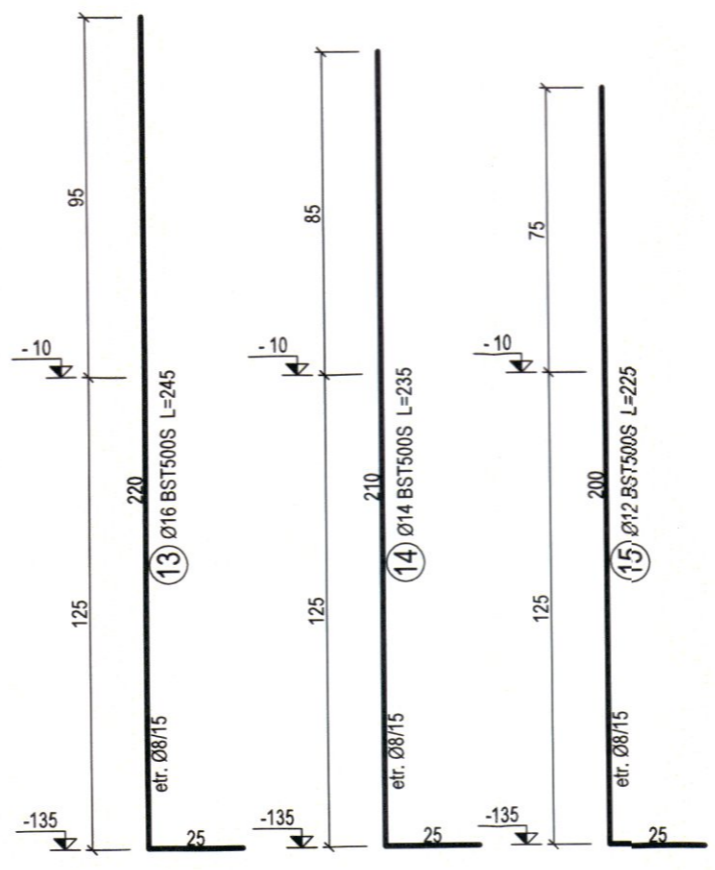

VERIFICAREA SI VALIDAREA PROIECTULUI

NERESPECTAREA INTOCMAI A PROIECTULUI, DE CATRE BENEFICIAR SAU CONSTRUCTOR, ABSOLVA PROIECTANTUL DE ORICE RASPUNDERE.

Verificatori/Experti:	Nume	Semnatura	Cerinta	Referat / Expertiza nr. data
VERIFICATOR:			A1, A2, A3	
EXPERT TEHNIC:				

<b>UP-Architecture</b> s.c. URBAN PLANNING ARCHITECTURE s.r.l. C.U.I. 39884638 J25/466/18.09.2018 E-mail: - uparchitecture@yahoo.com		BENEFICIAR: <b>U.A.T. PRUNISOR</b>	Proiect numar: 70.24/UPA
Sef proiect arh. Sorin Puiu BARLAN	SEMNATURA 	SC: 1/20	OBIECTIV: Demolare cladire existenta C1 si Construire gradinita doua grupe AMPLASAMENT: nr. cad. 51367, comuna Prunisor, sat Prunisor, jud. Mehedinti
Proiectat ing. Jeff PLOIA	SEMNATURA 	DATA: 01/2025	Faza: D.T.A.C.-P.T.
Desenat ing. Jeff PLOIA			Titlu pagina: DETALII FUNDATII Plansa numar: R-07

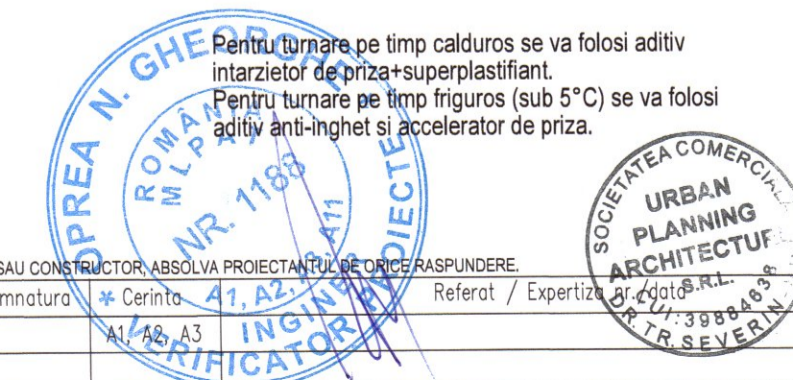
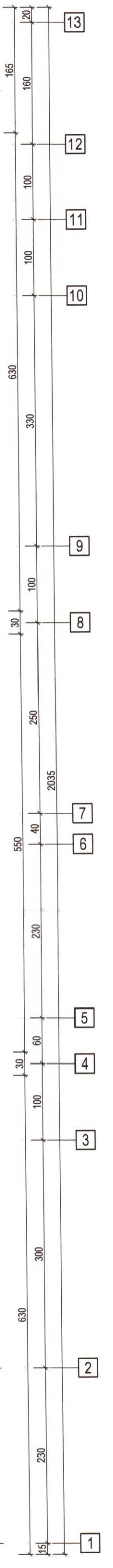
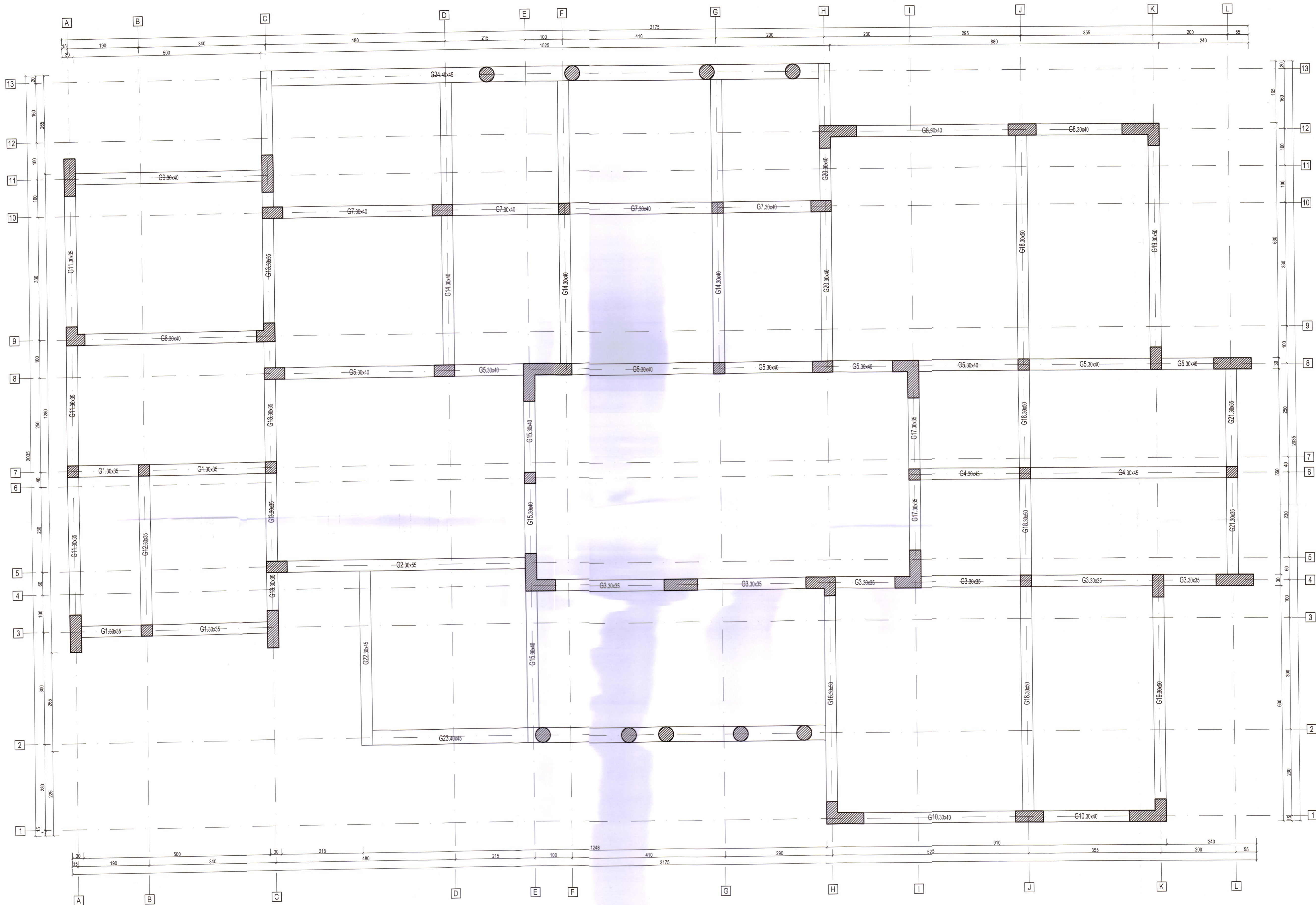

Verificatori/Experti: \_\_\_\_\_

Verificator: \_\_\_\_\_

Expert tehnic: \_\_\_\_\_

NOTA: \_\_\_\_\_

CONFORM HG766/1997, CONSTRUCTIA SE INCADREAZA IN CATEGORIA DE IMPORTANTANTA "C".  
CONFORM P100-1/2019, ZONA SEISMICA ESTE CARACTERIZATA DE  $a_g = 0.15g$ ,  $T_c = 0.7$  sec.

s.c. URBAN PLANNING ARCHITECTURE s.r.l. CUI 3884638   024481322016 Email: up@urbanplanning.ro		BENEFICIAR
NUMELE	SEMNATURA	SC.
arh. Sorin Puiu BARLAN	<i>[Signature]</i>	1/50
Proiectat	ing. Jeff PLOIA	DATA:
Desenat	ing. Jeff PLOIA	01/2025
OBJECTIV: Demolare cladire vechi si Construire gradinita doua grupuri		Faza:
AMPLASAMENT: nr. cal. 51387, comuna Prunisor, sat Prunisor, jud. Mehedinți		D.T.A.C.-P.T.
TITLU PAGINA: PLAN GRINZI PESTE PARTER, COTA +345, +395, +445		Plansa numar
		R-08

Armare G1 30x35, ax 3, ax 7  
2 buc.

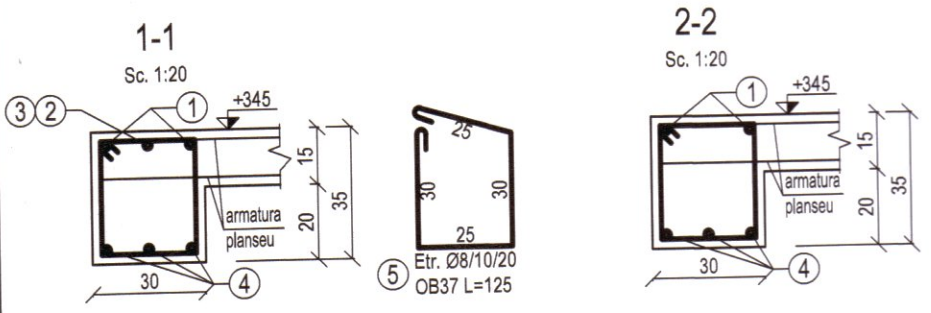
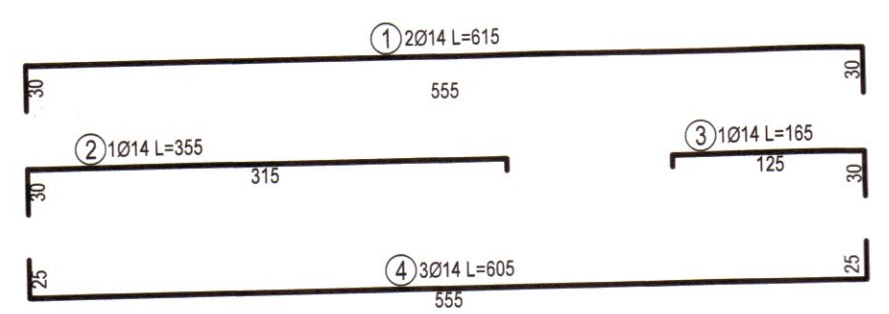
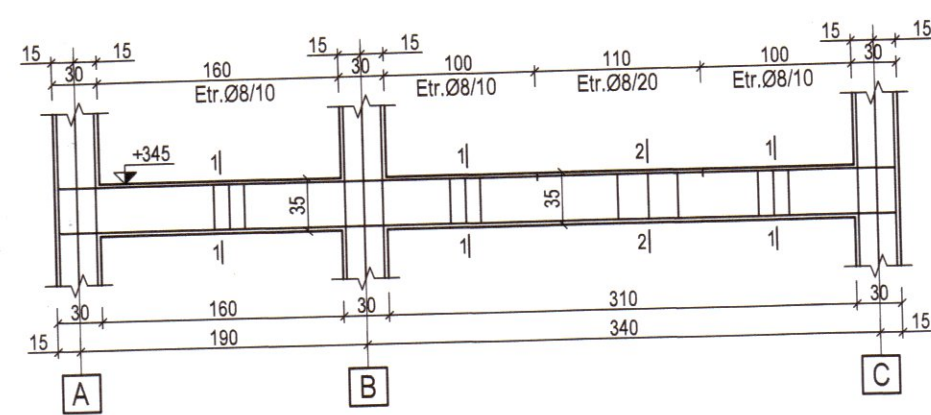

Armare G2 30x55, ax 5  
1 buc.

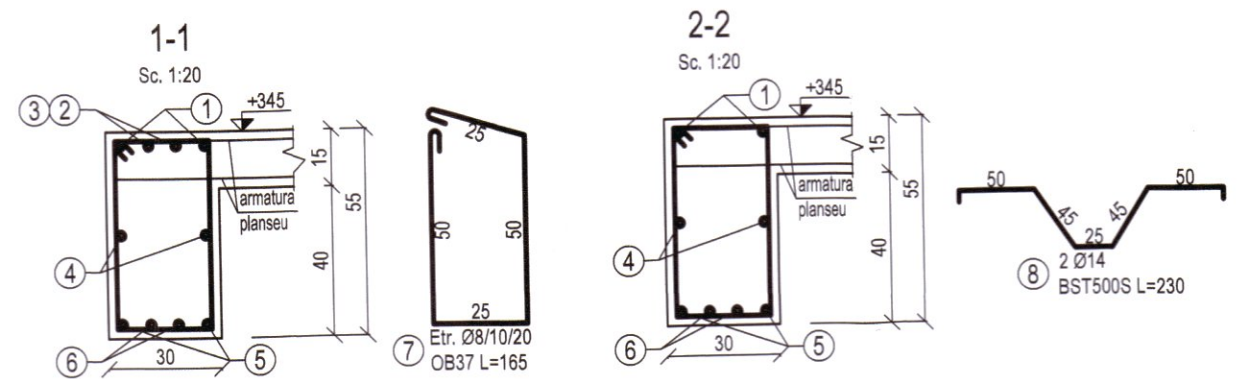
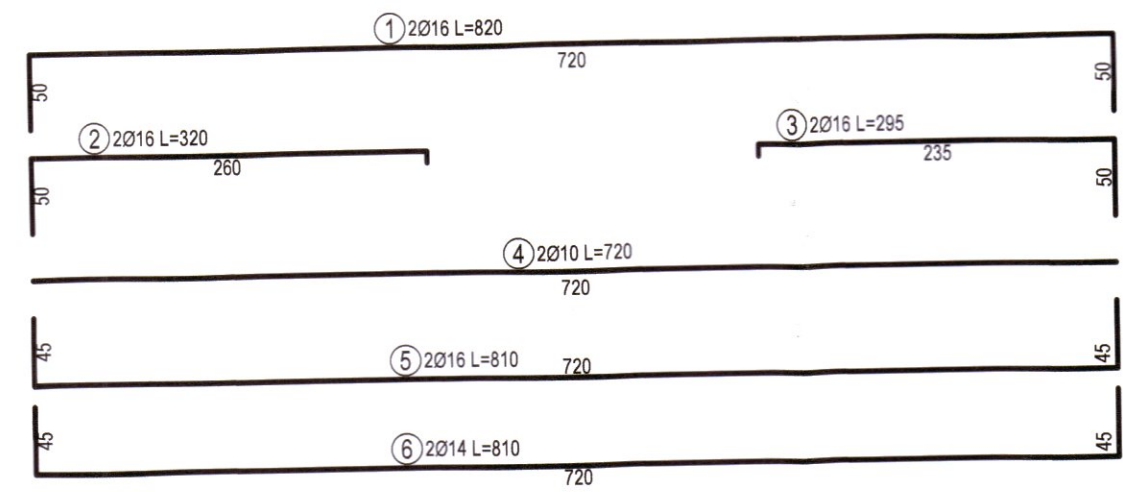
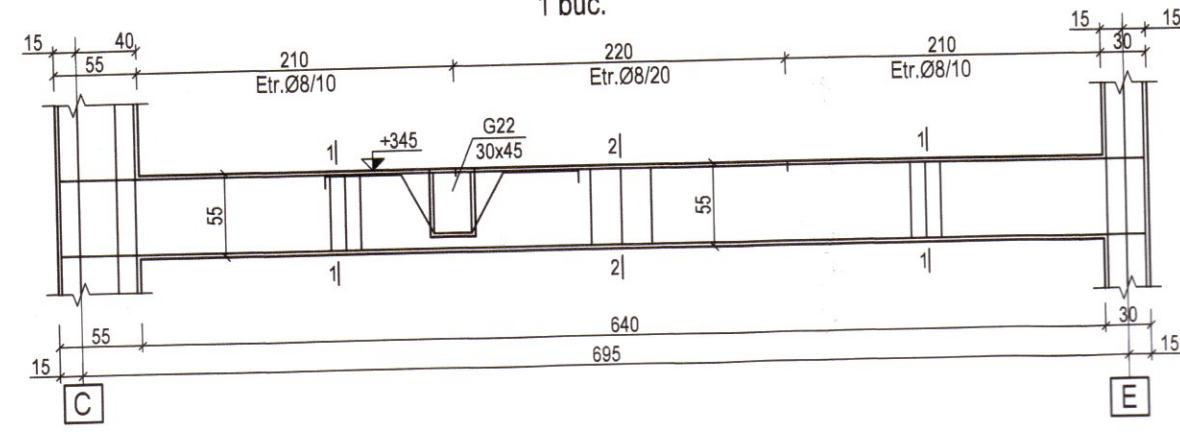

Armare G3 30x35, ax 4  
1 buc.

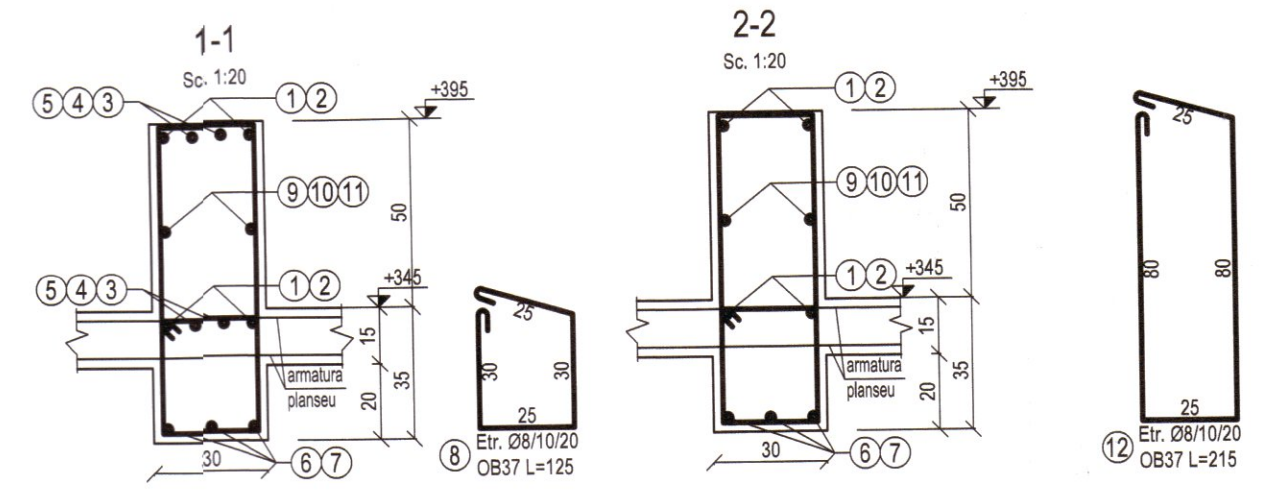
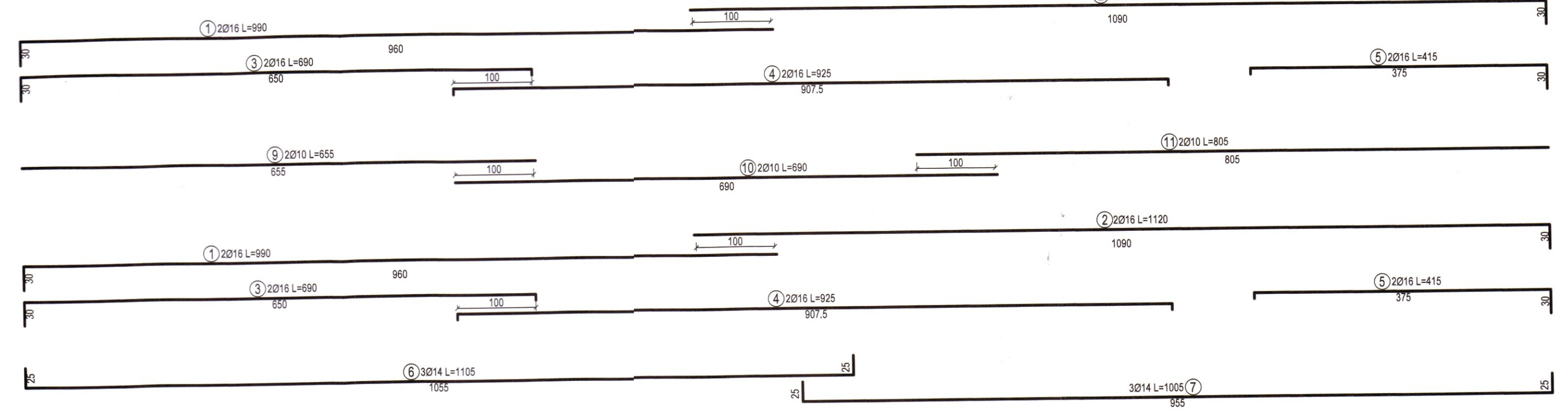
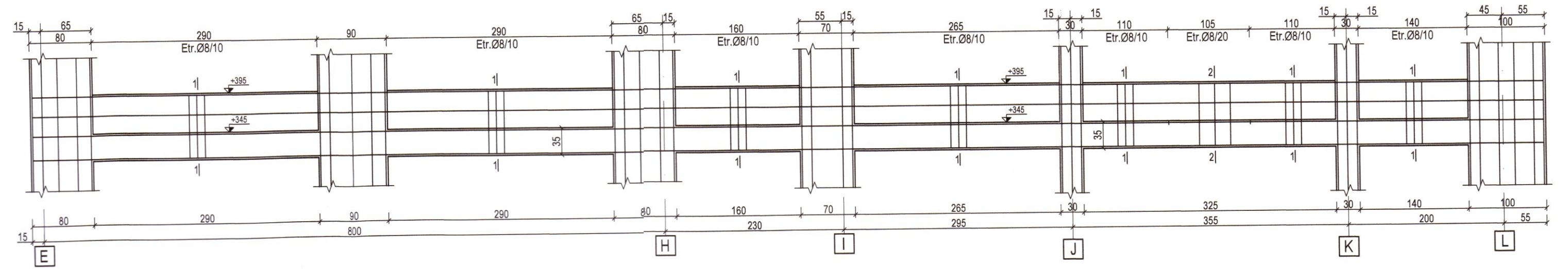

Armare G5 30x40, ax 8  
1 buc.

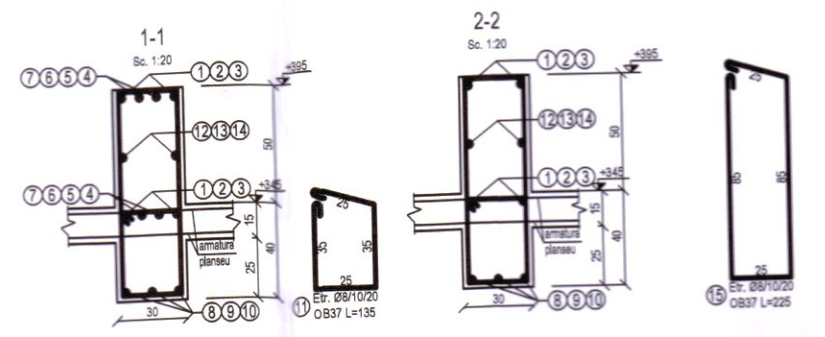
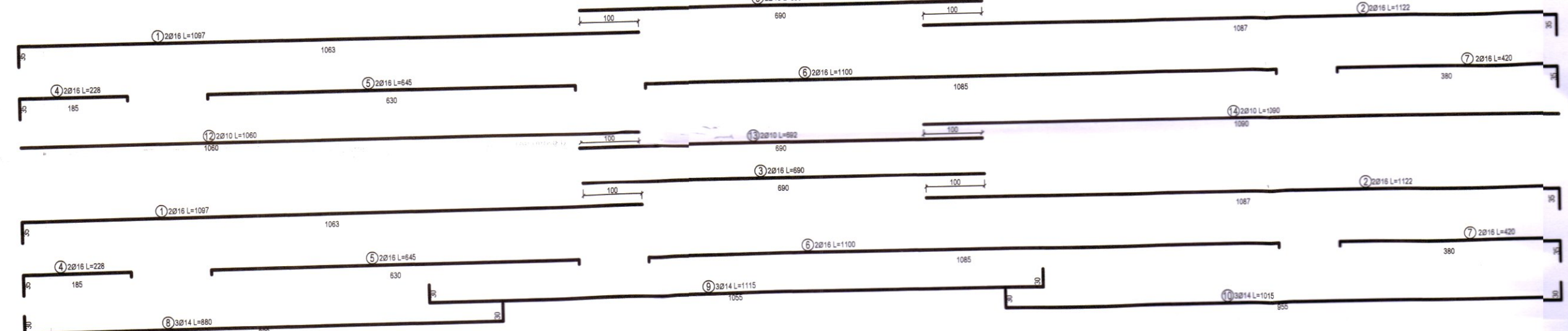
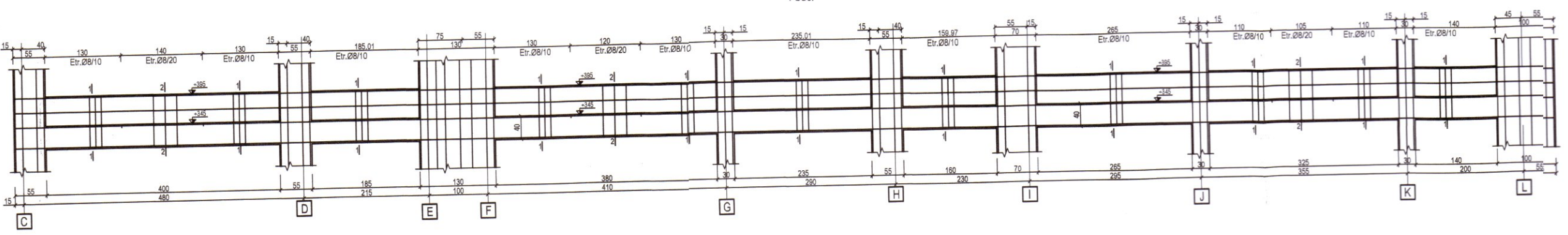

Armare G8 30x40, ax 12  
1 buc.

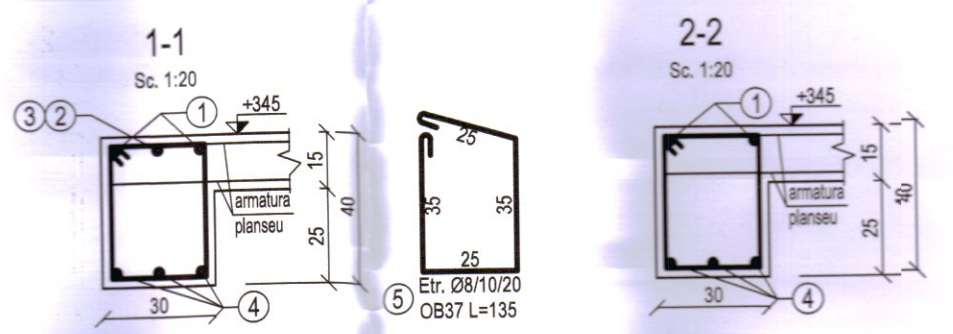
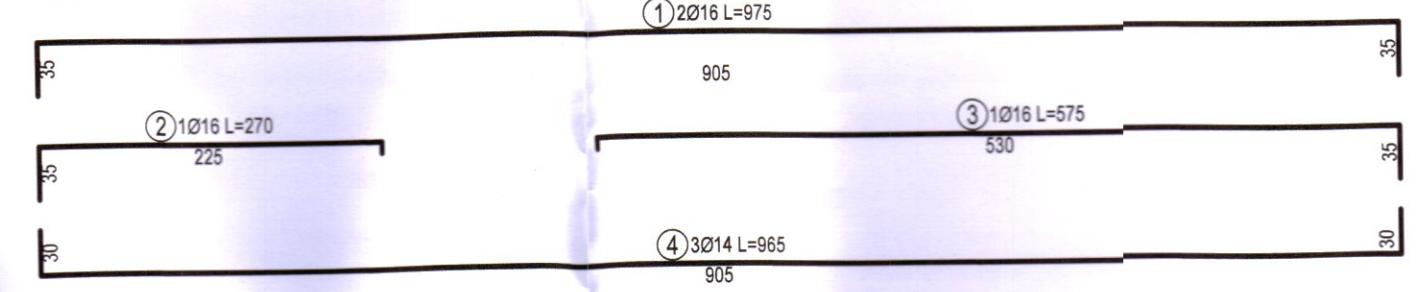
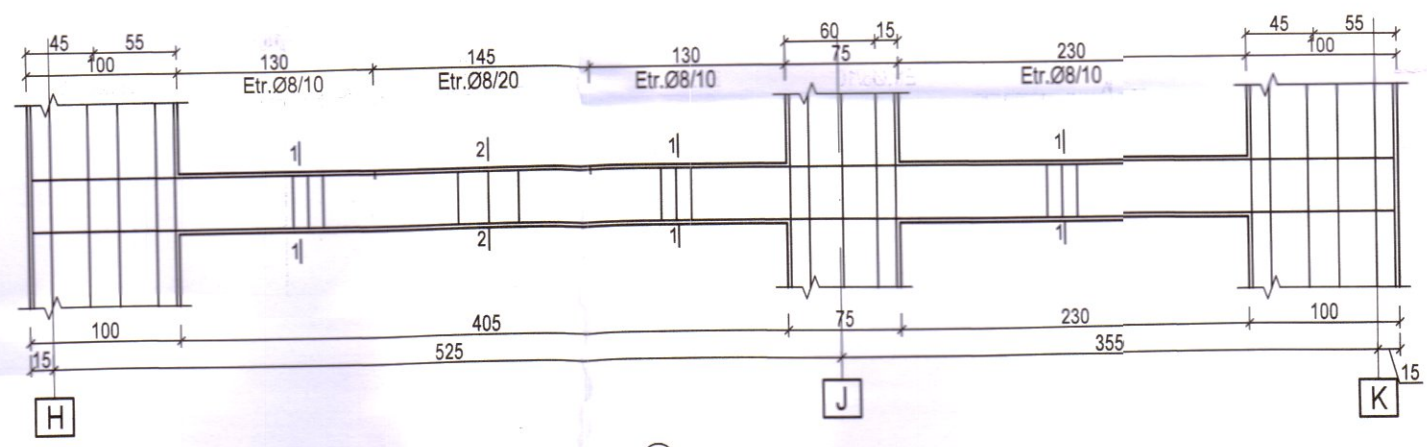

Armare G4 30x45, ax 6  
1 buc.

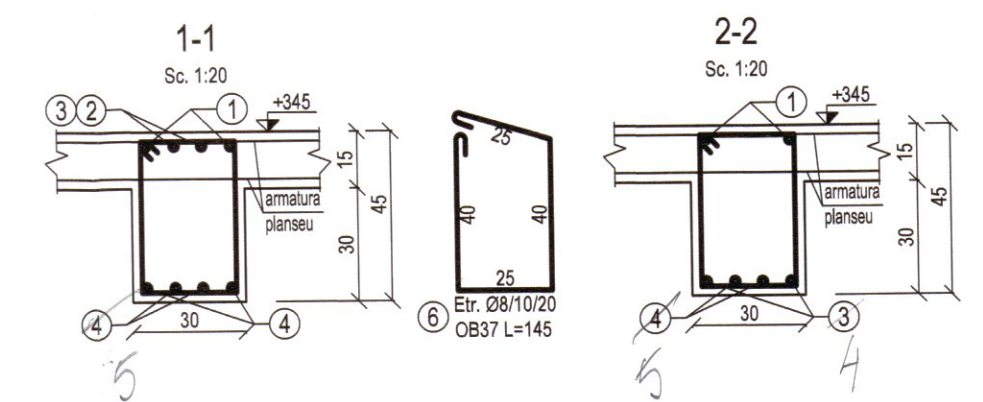
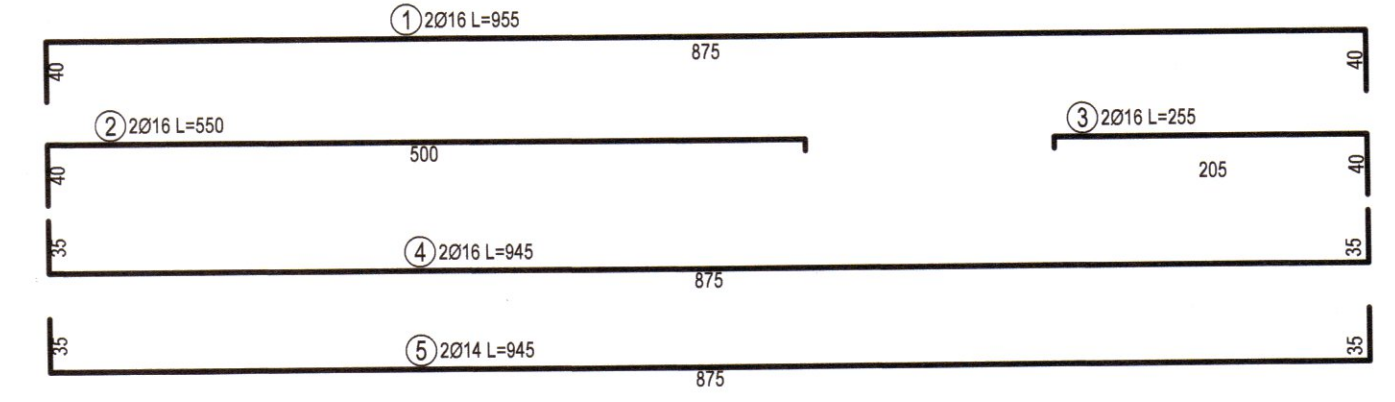
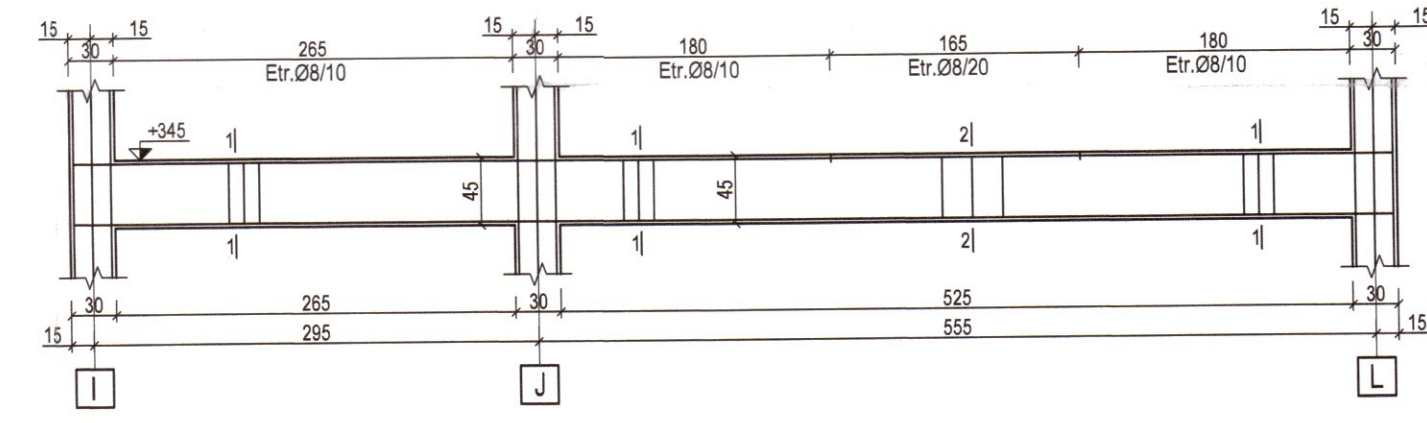

Armare G7 30x40, ax 10  
1 buc.

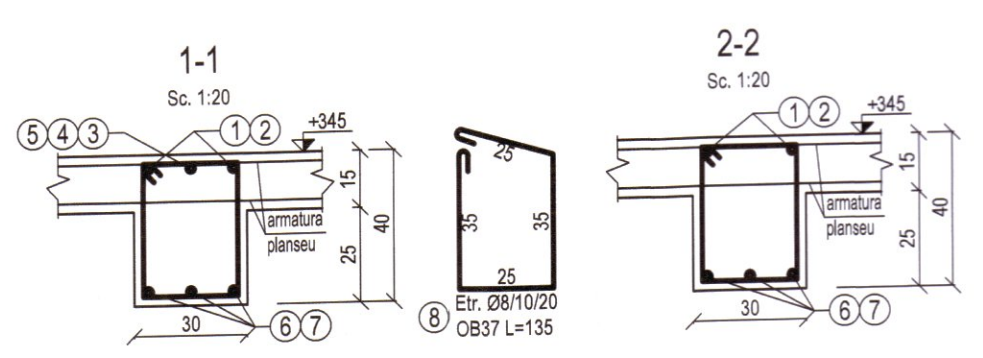
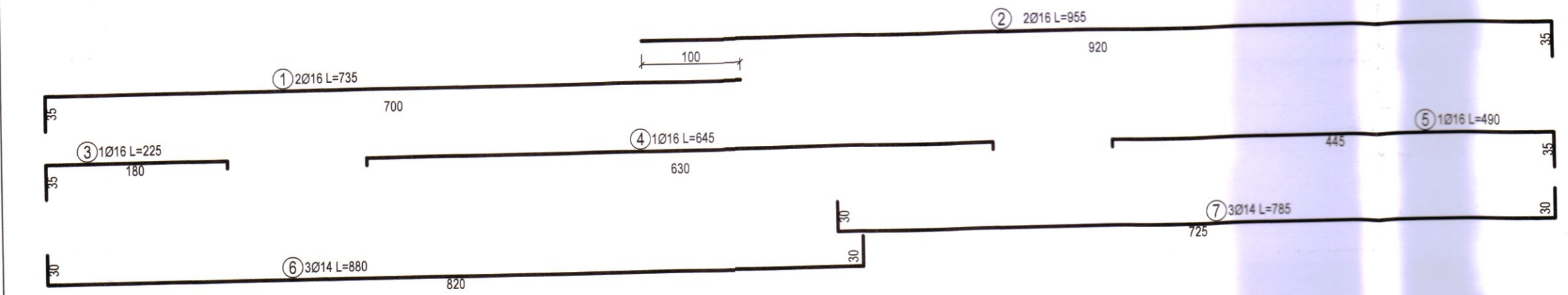
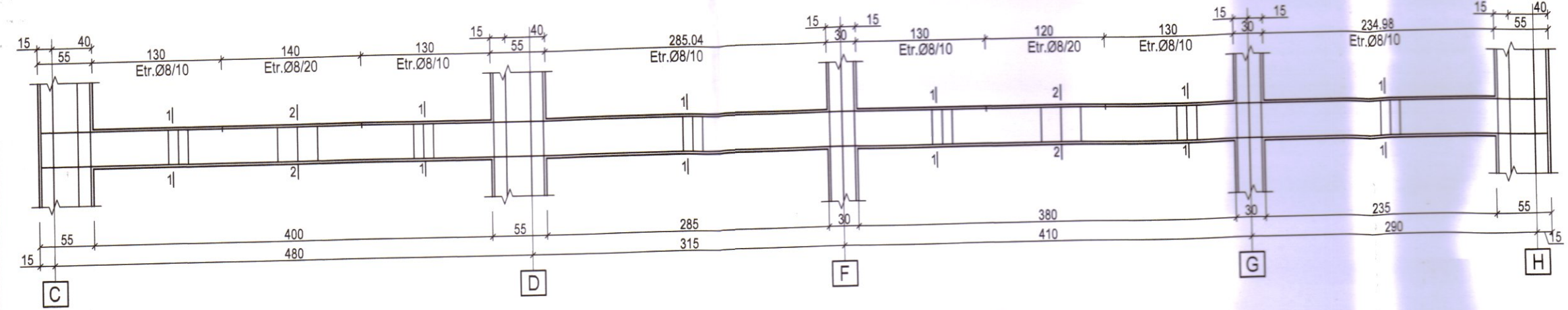

Armare G6 30x40, ax 9  
1 buc.

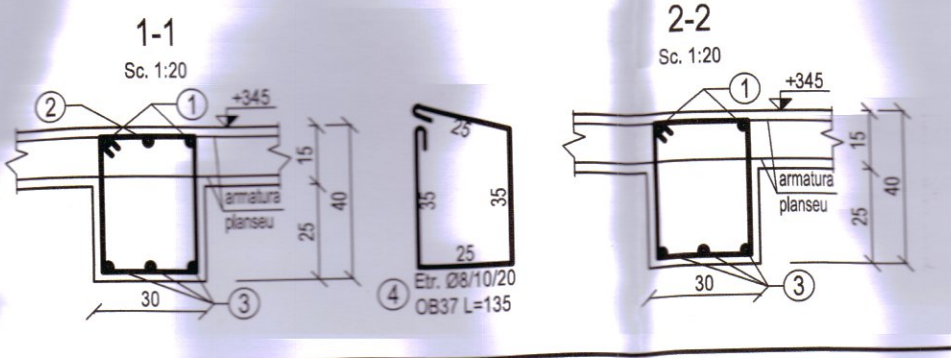
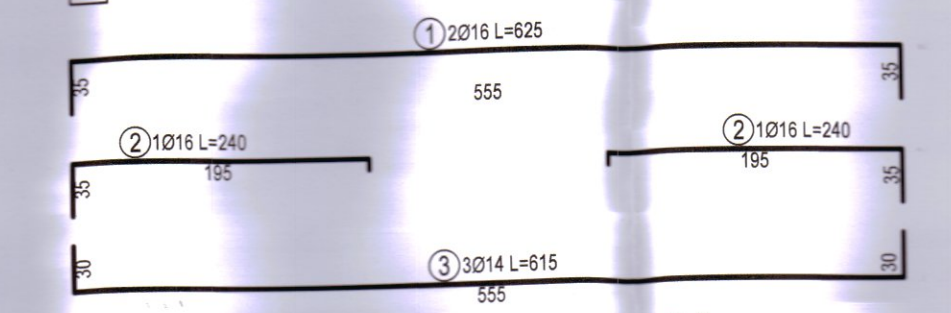
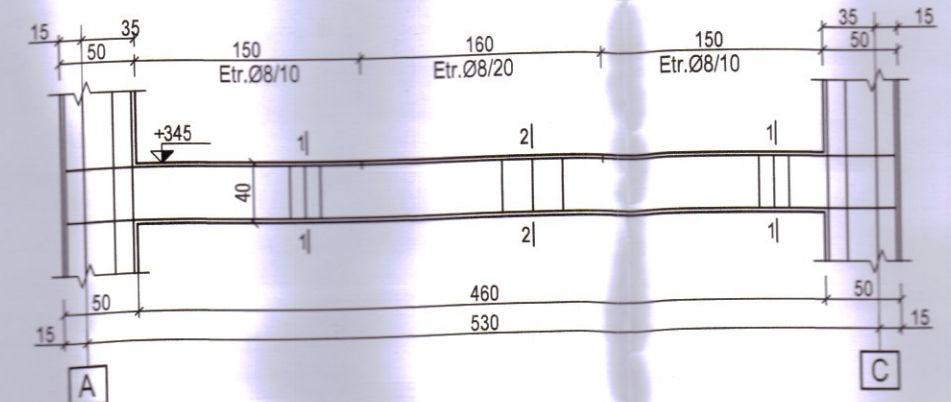

Armare G9 30x40, ax 11  
1 buc.

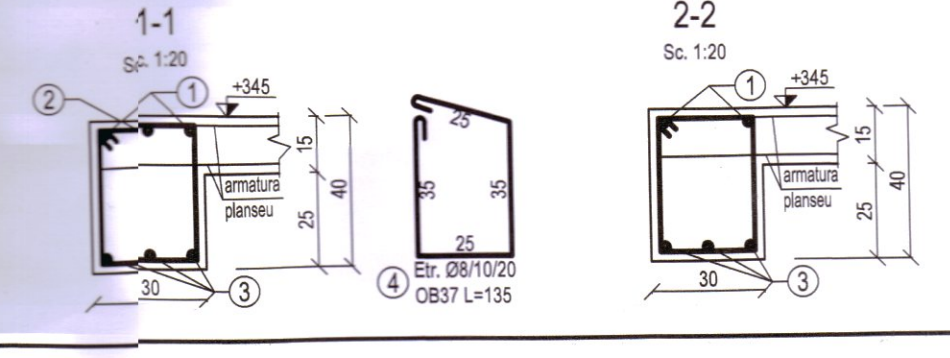
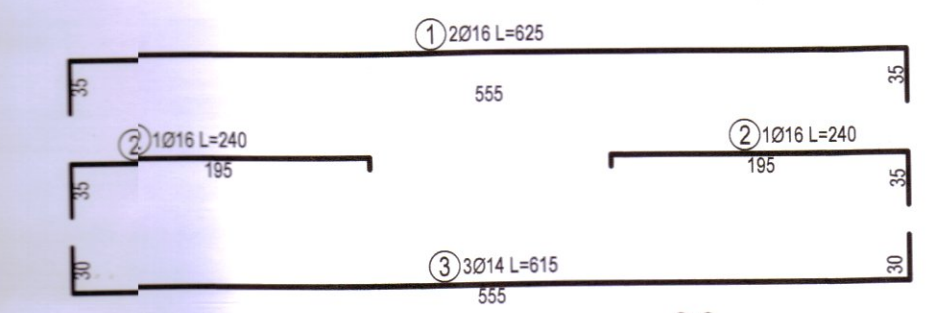
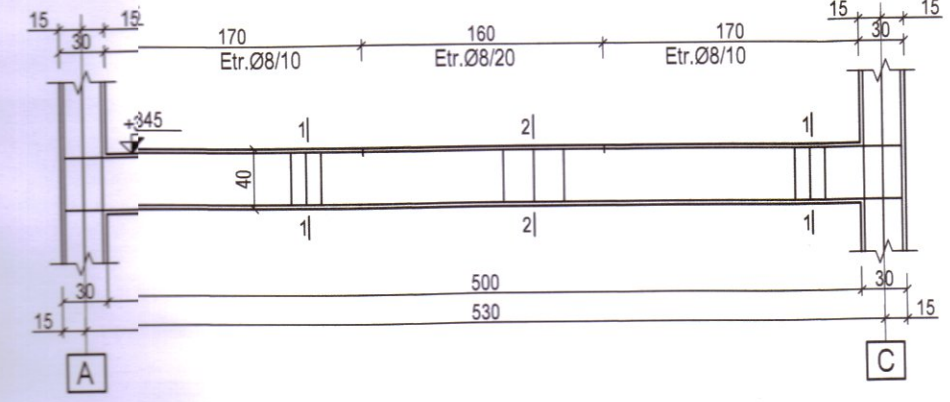

Beton	C 8/10 - B 150
	C 16/20 - B 250
Otel	OB 37
	BST500S

Pentru turnare pe timp calduros se va folosi aditiv intarziator de priza+superplastifiant.  
Pentru turnare pe timp friguros (sub 5°C) se va folosi aditiv anti-inghet si accelerator de priza.

UP-Architecture s.c. URBAN PLANNING ARCHITECTURE S.R.L.  
CUI: 3884639 2048/19.03.2016  
E-mail: uparh@uparh.ro

U.A.T. PRUNISOR

PROIECTANTUL DE OBLIGATORIE RASPUNZARE

Verificator/Expert:	Nume	Semnatura	Categoria	Referinta	Experienta nr./an
VERIFICATOR:			A1, A2, A3		
EXPERT TEHNIC:					

NUMELE SEMNATURA SC: 150  
am. Sorin Puiu BARLAN  
Controlat gradinita doua grup  
Proiectat: Ing. Jeff PLOIA  
Desenat: Ing. Jeff PLOIA

OBIECTUL: Sonda de date existenta C1 si  
Controlat gradinita doua grup  
AMPLASAMENT: nr. cad. 51387, comuna Prunisor, sat Prunisor, jud. Mehedinți  
TITLU PAGINA: DETALII ARMARE GRINZI PESTE PARTER COTA +345, +395, +445  
DATA: 01/2025

Project num 70.24/UPA  
Faza: D.T.A.C.-P  
Planşa num R-09

Armare G10 30x40, ax 1  
1 buc.

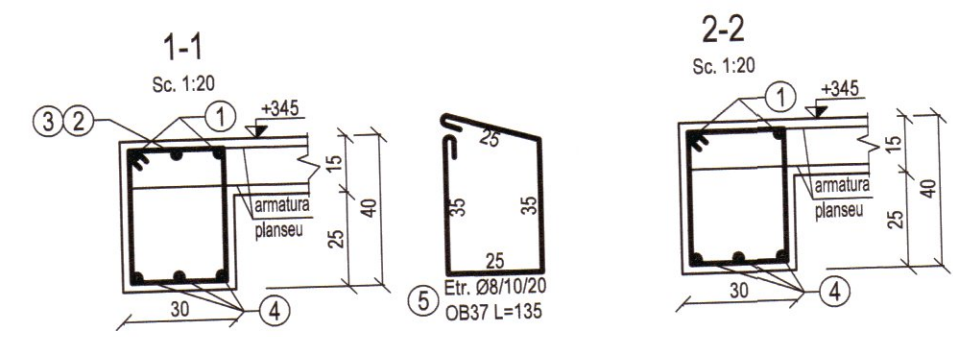
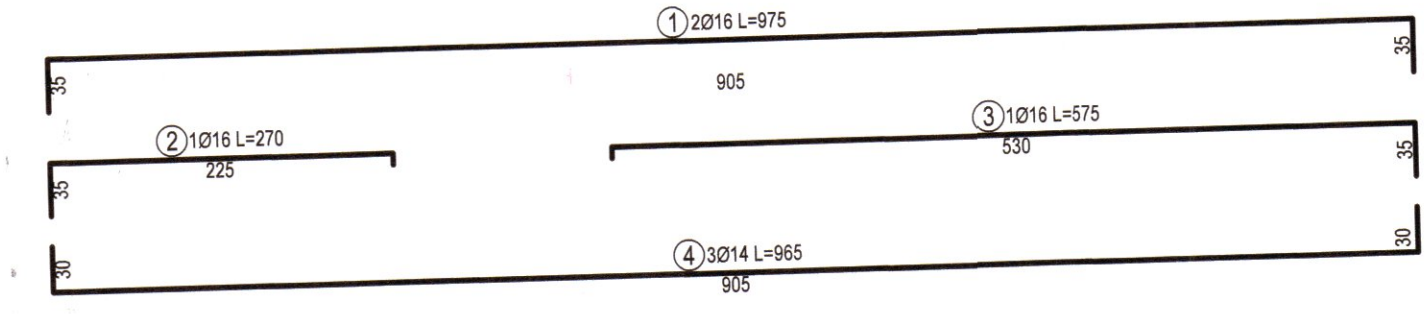
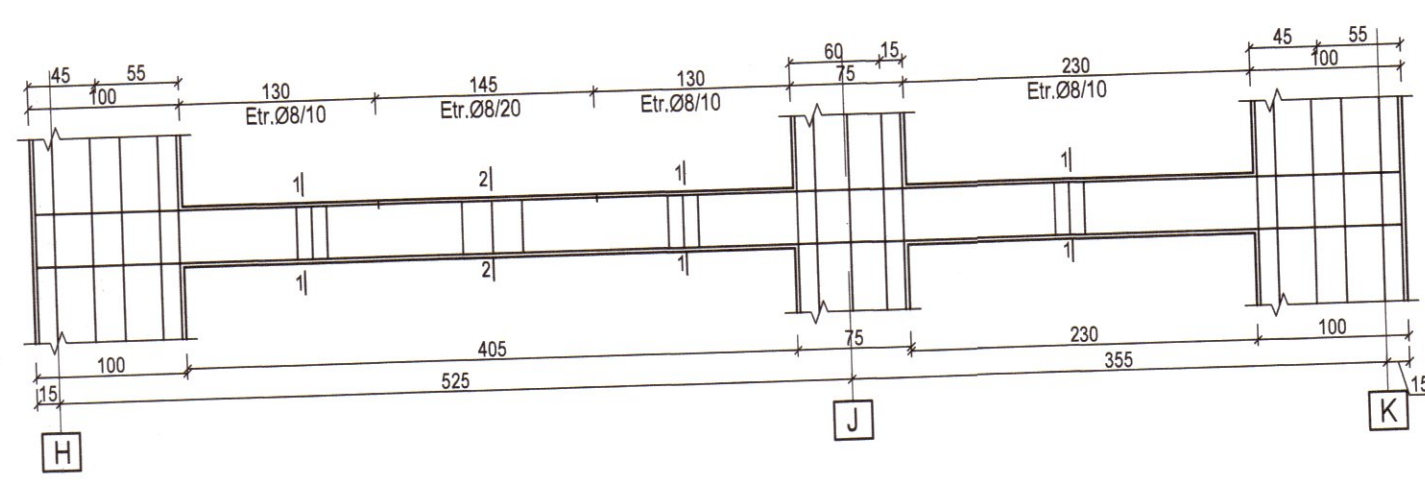

Armare G12 30x35, ax B  
2 buc.

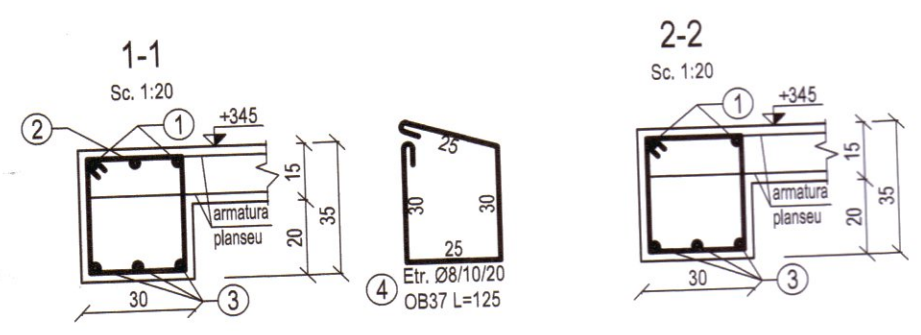
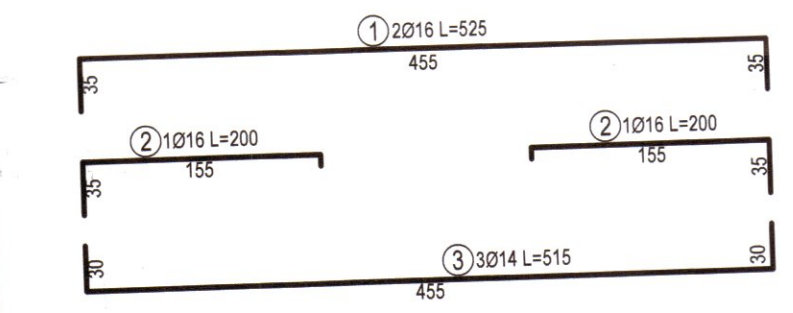
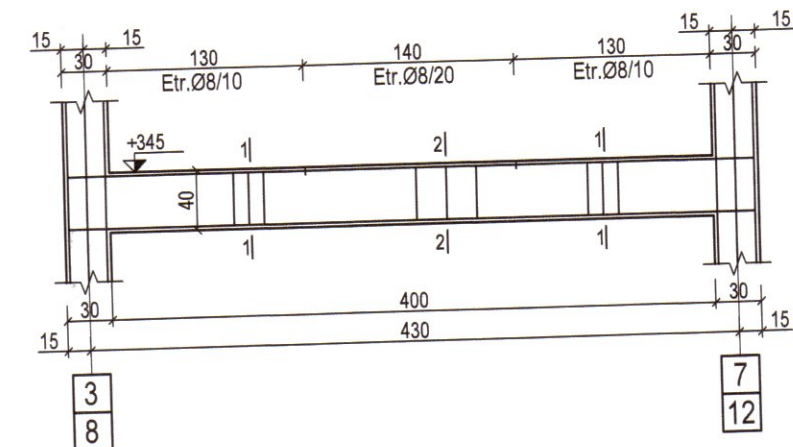

Armare G14 30x40, ax D, F, G  
3 buc.

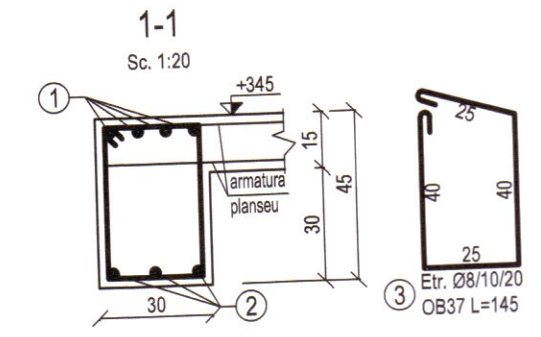
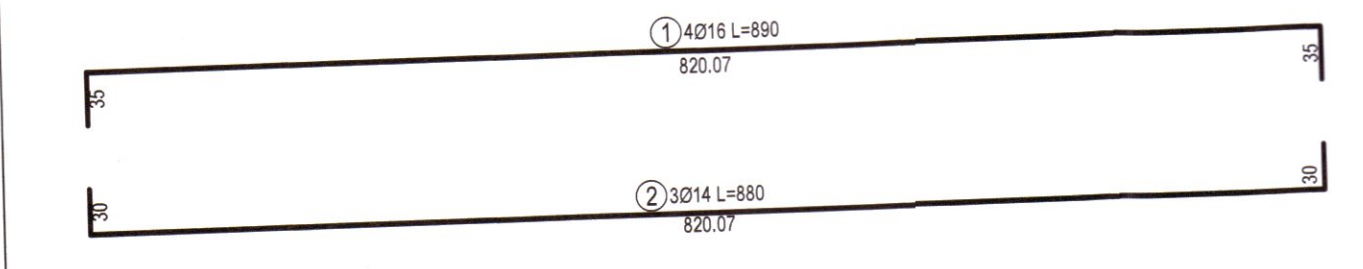
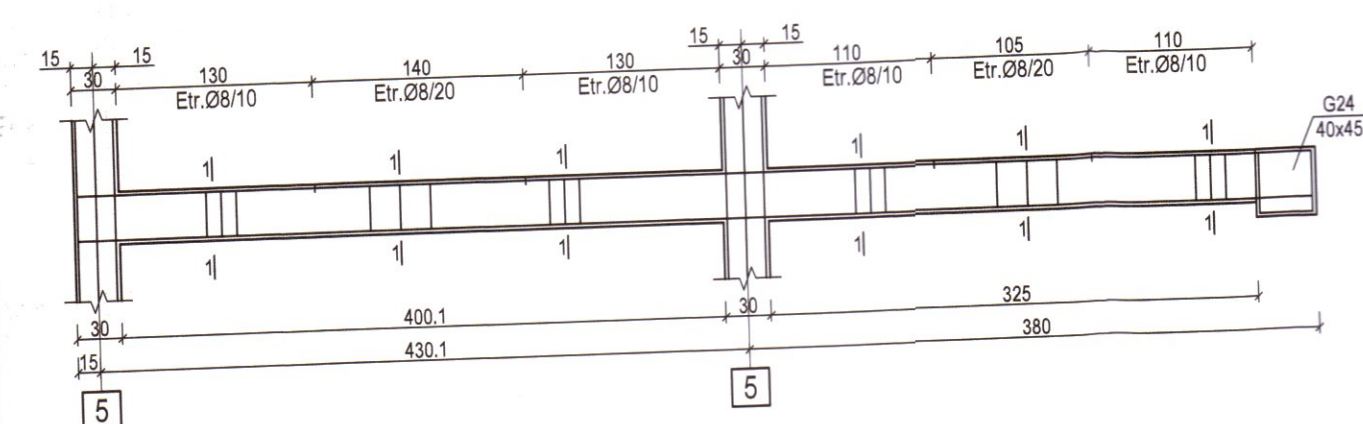

Armare G11 30x35, ax A  
1 buc.

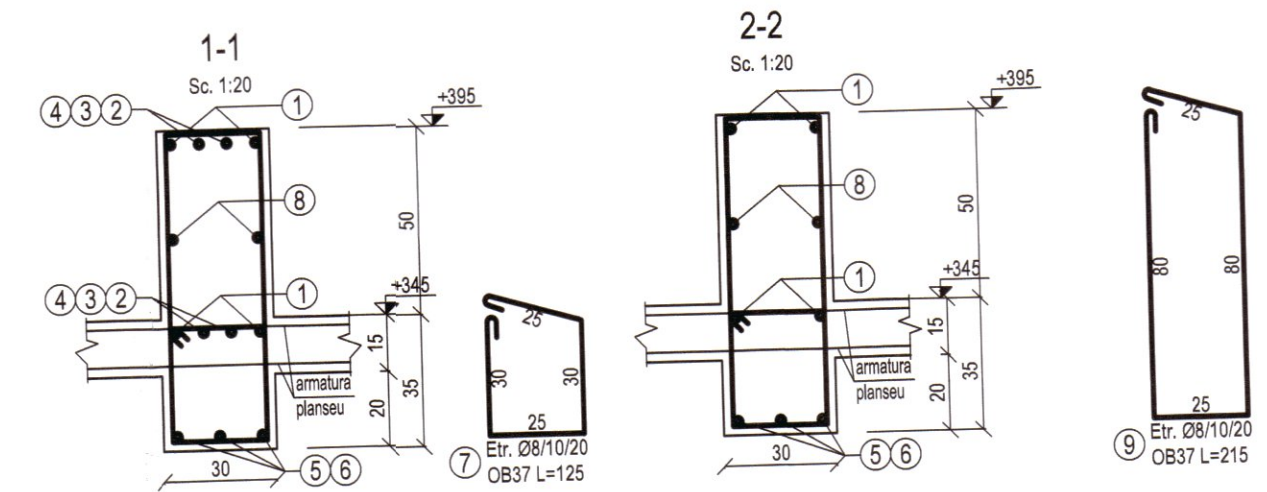
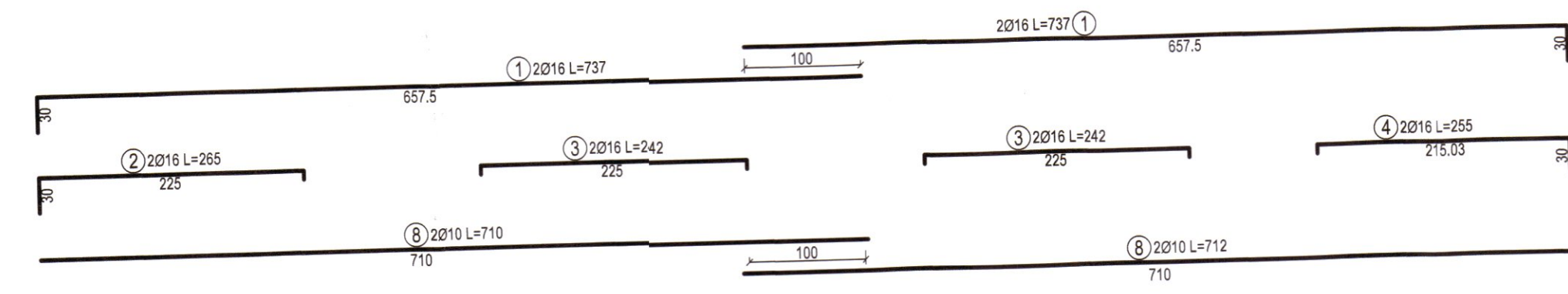
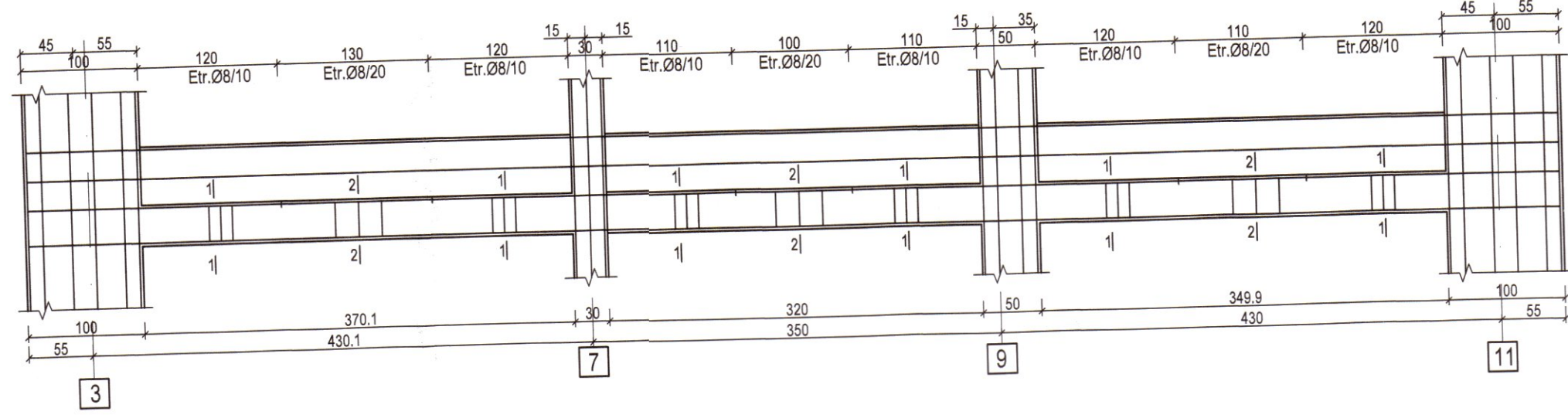

Armare G15 30x40, ax E  
1 buc.

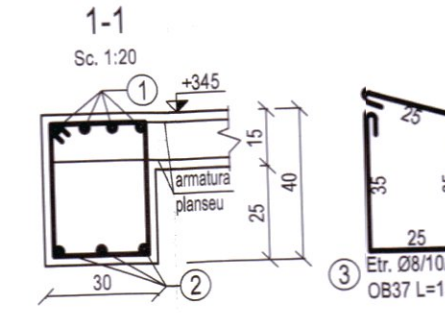
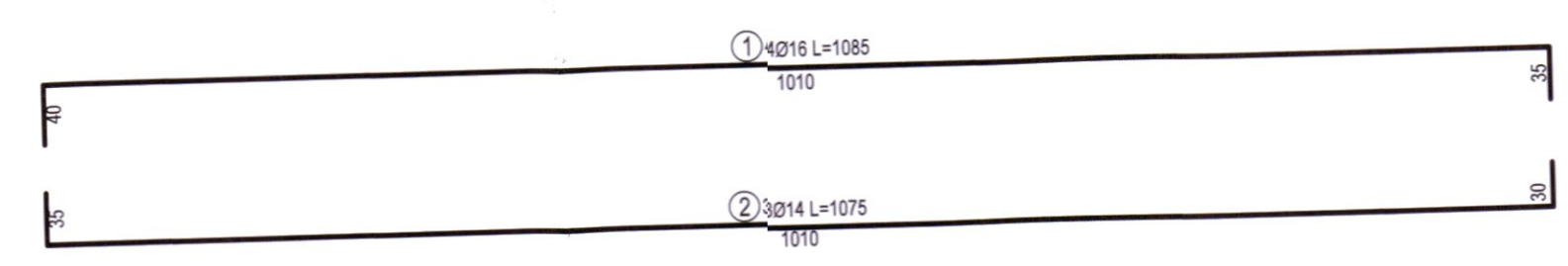
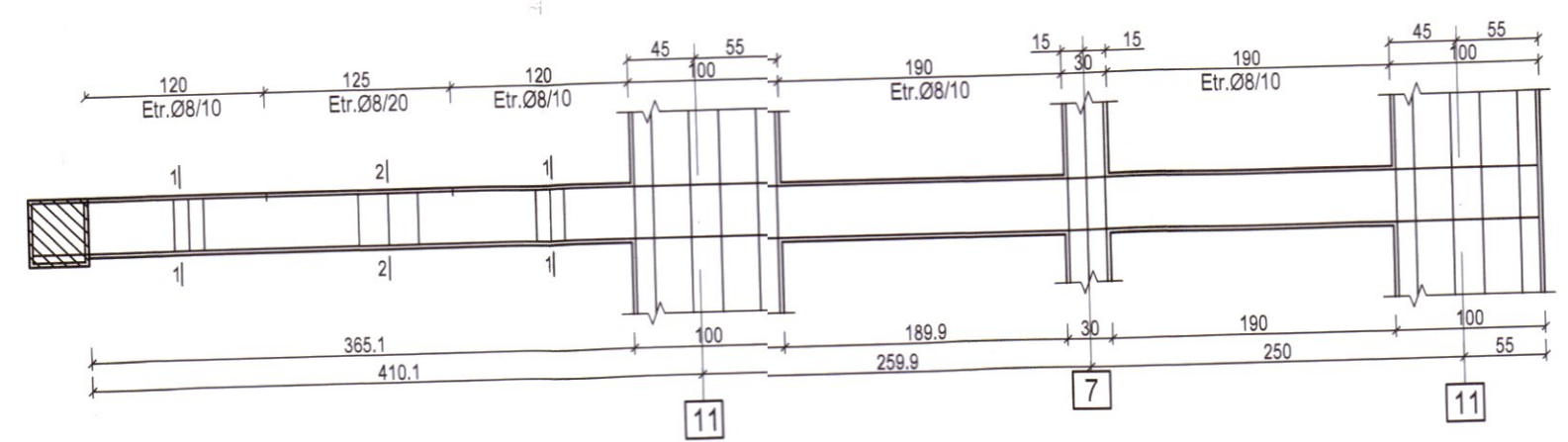

Armare G17 30x35, ax I  
1 buc.

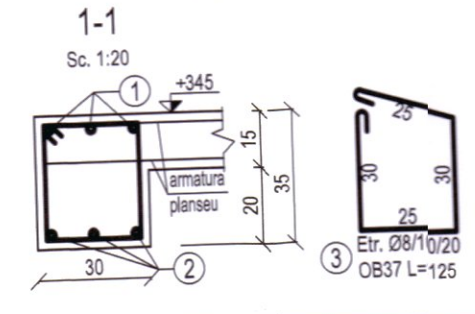
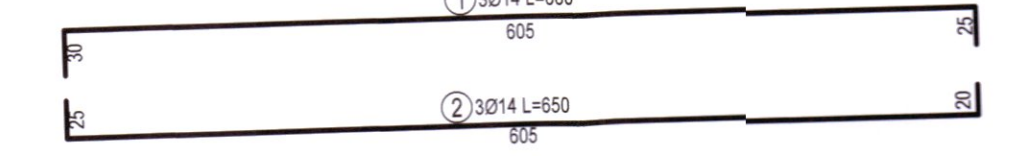
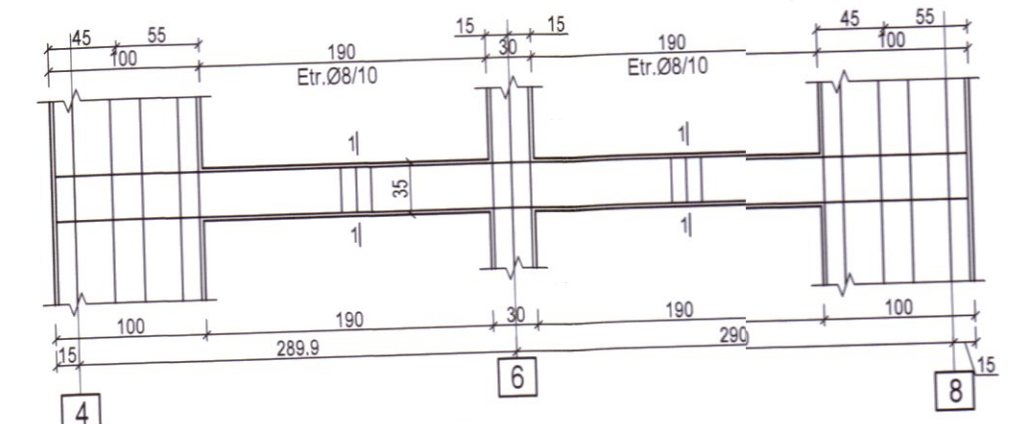

Armare G13 30x35(45), ax C  
1 buc.

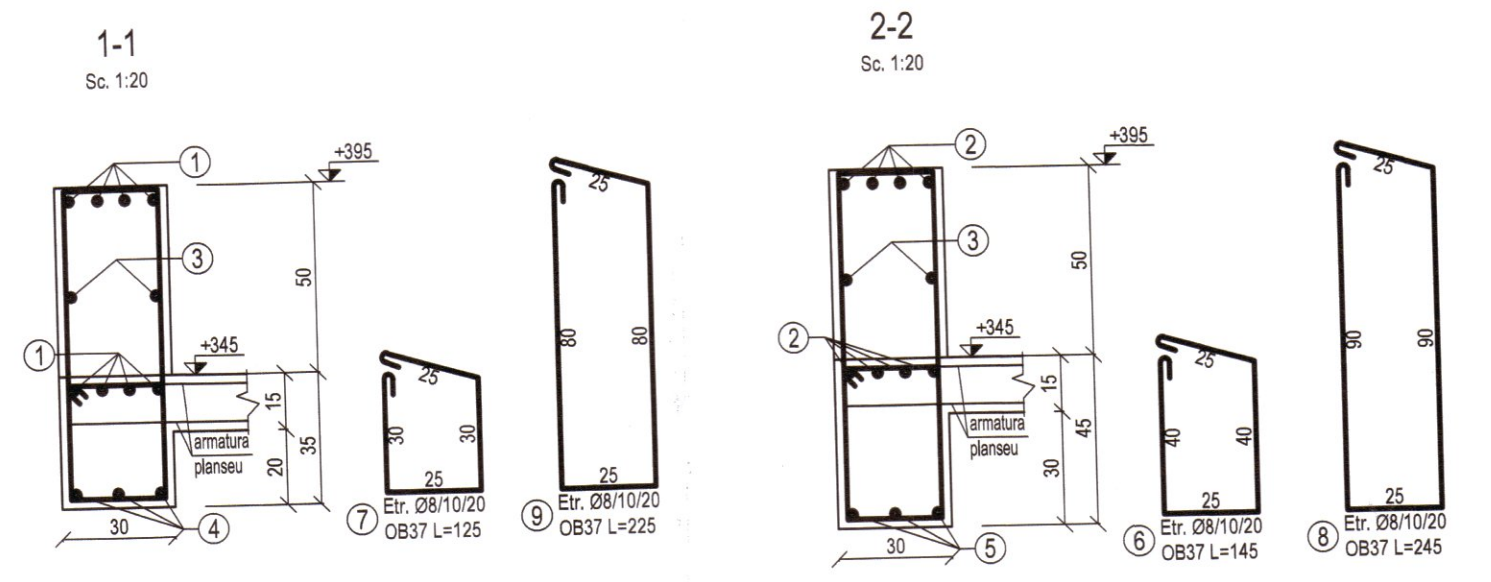
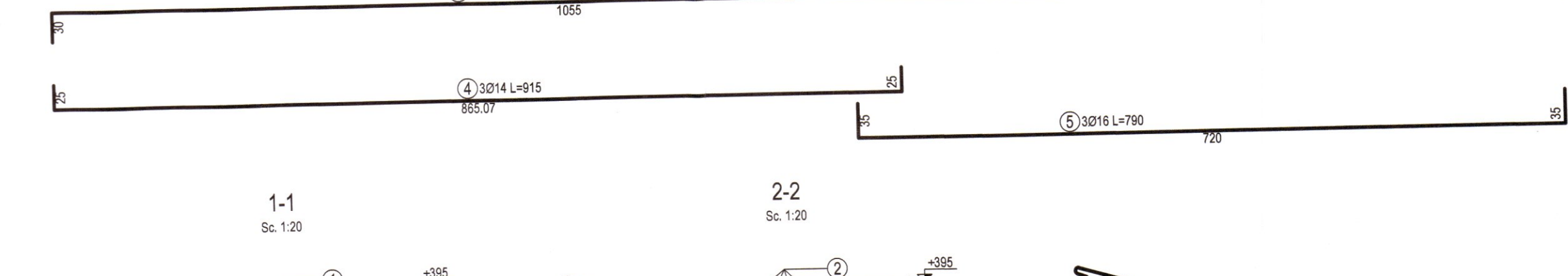
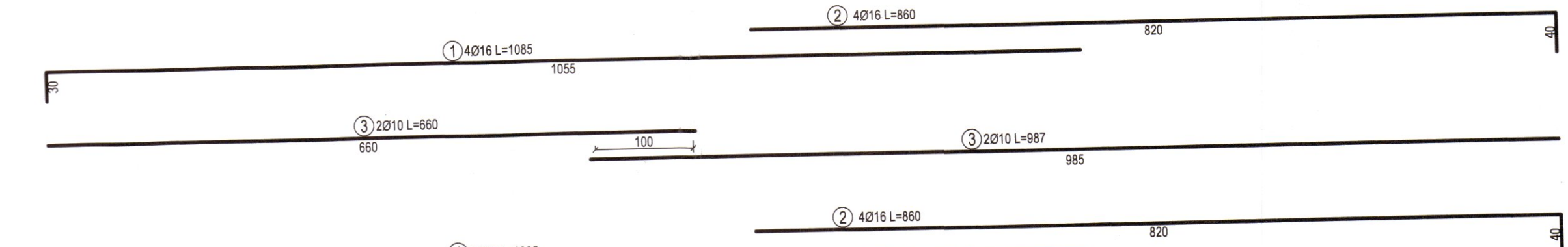
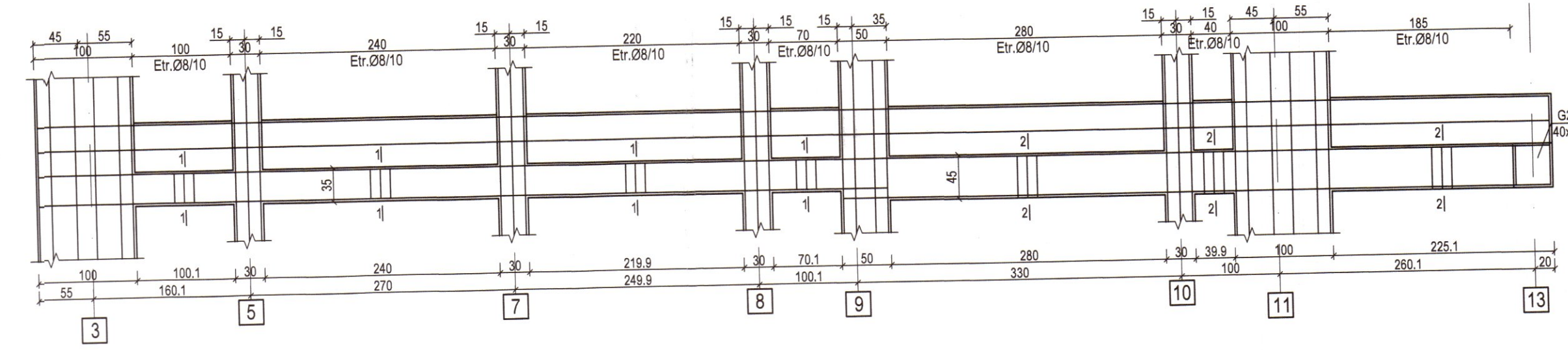

Armare G16 30x50, ax H  
1 buc.

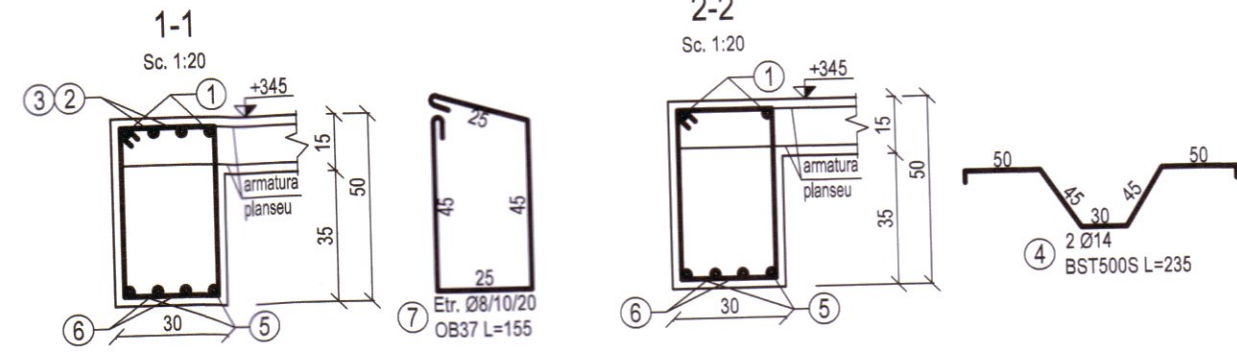
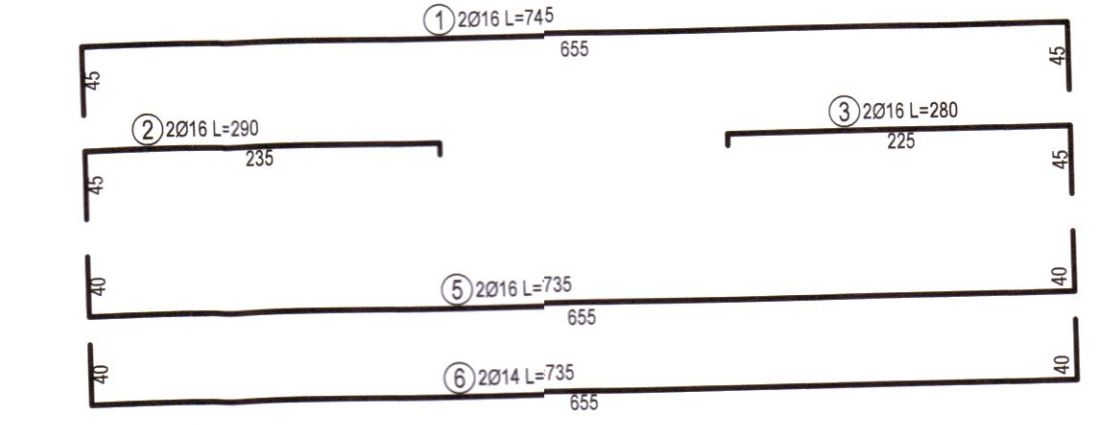
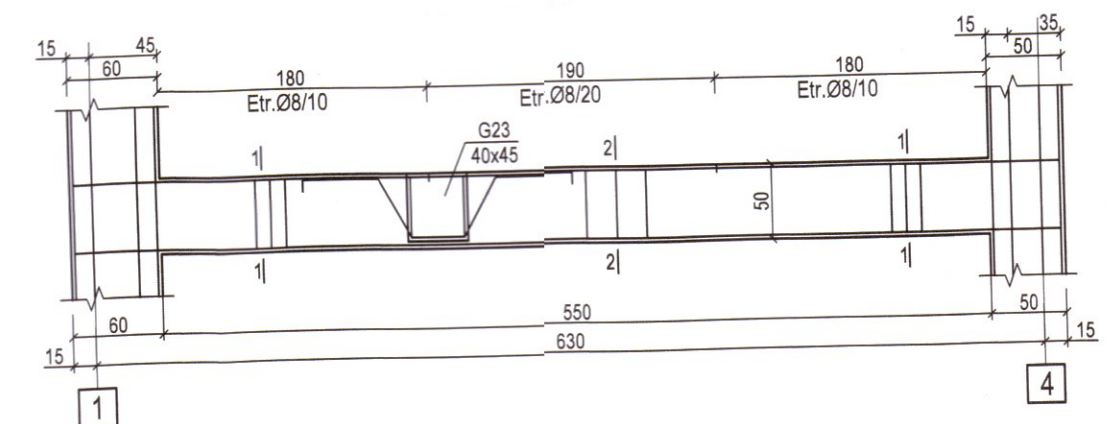

Armare G19 30x50, ax K  
1 buc.

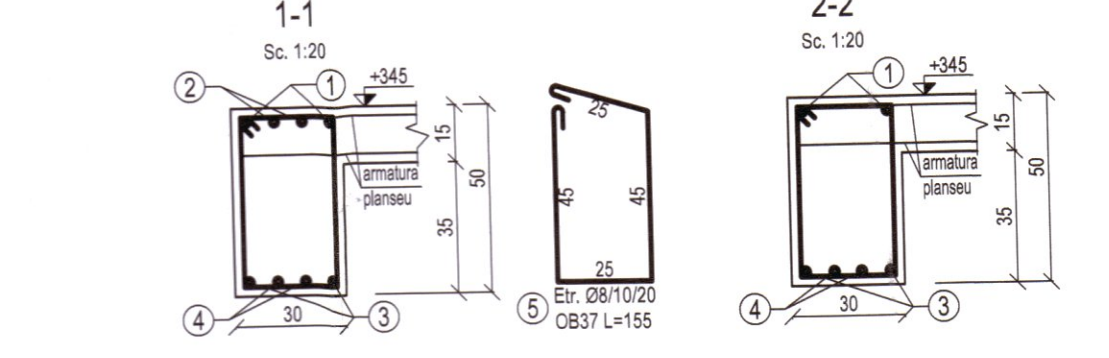
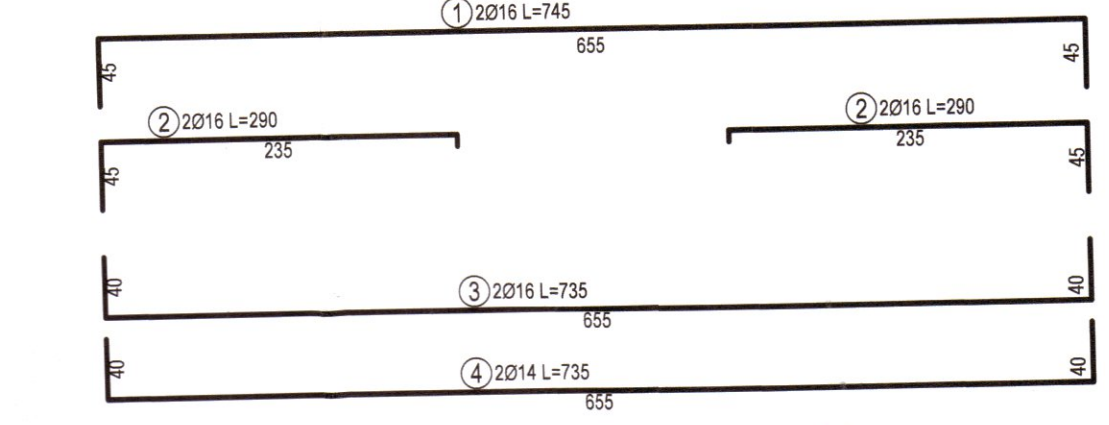
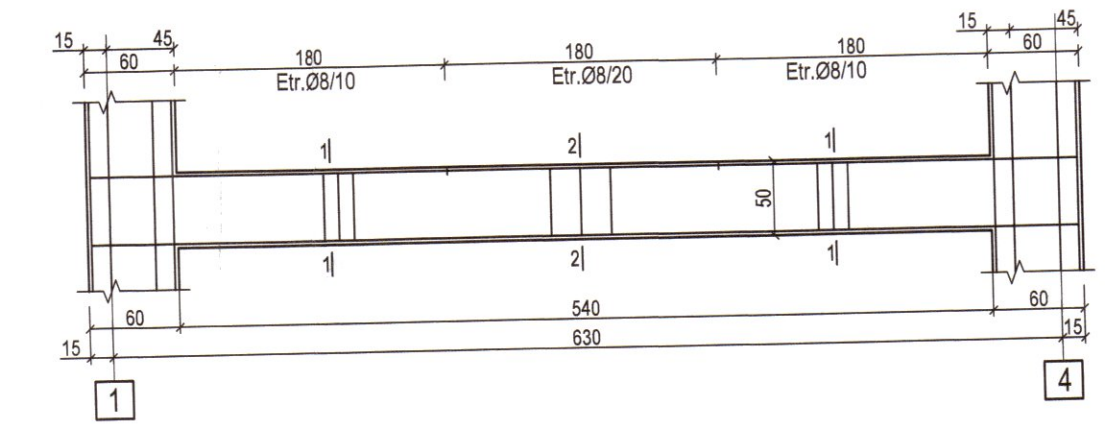

Beton C 8/10 - B 150  
C 16/20 - B 250  
Otel OB 37  
BST500S

Pentru turnare pe timp calduros se va folosi aditiv intarziator de priza+superplastifiant.  
Pentru turnare pe timp friguros (sub 5°C) se va folosi aditiv anti-frignet si accelerator de priza.

RESPECTAREA INTOACMI A PROIECTULUI, DE CATRE BENEFICIAR SAU CONSTRUCTOR, ABSOLUT PROHIBITIV, DE ORICE RASPUNDE.

VERIFICATOR/Expert: \_\_\_\_\_

VERIFICATOR: \_\_\_\_\_

EXPERT TEHNIC: \_\_\_\_\_

BENEFICIAR: \_\_\_\_\_

**UP-Architecture** s.c. URBAN PLANNING ARCHITECTURE s.r.l.  
CUI: 5969038 | 025491832919 | E-mail: up-architecture@uparho.com

**U.A.T. PRUNISOR**

Proiectant: ing. Jeff FLOIA  
Desenat: ing. Jeff FLOIA

SC: 1/50  
DATA: 01/2025

OBIECT: Demolare cladire existenta C1 si Constructie gradinita doua grupe  
AMPLASAMENT: nr. cad. 51367, comuna Prunisor, sat Prunisor, jud. Mehedinti

TITLU PAGINA: DETALII ARMARE GRINZI PESTE PARTER COTA +345, +395, +445

Planșă nr. \_\_\_\_\_

Armare G18 30x50, ax J  
1 buc.

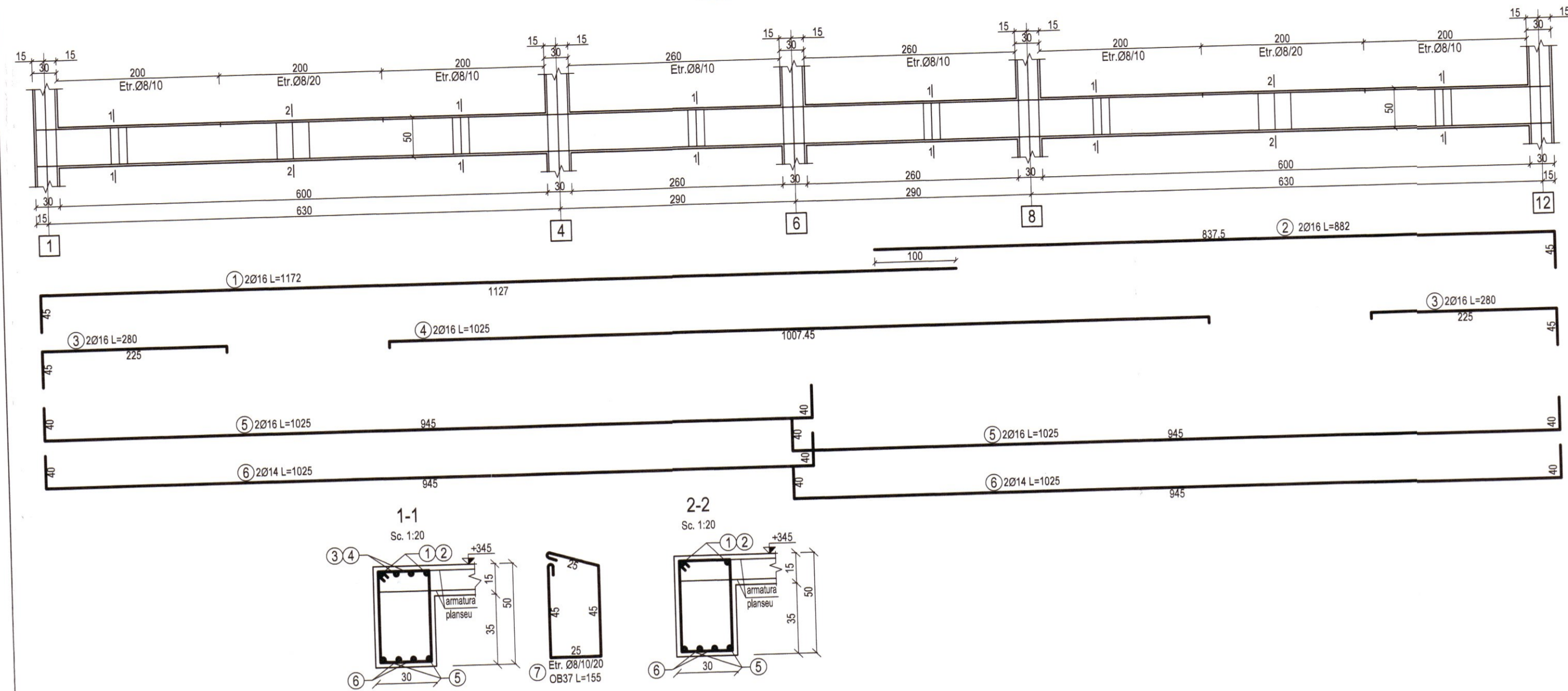

Armare G24 30x45  
1 buc.

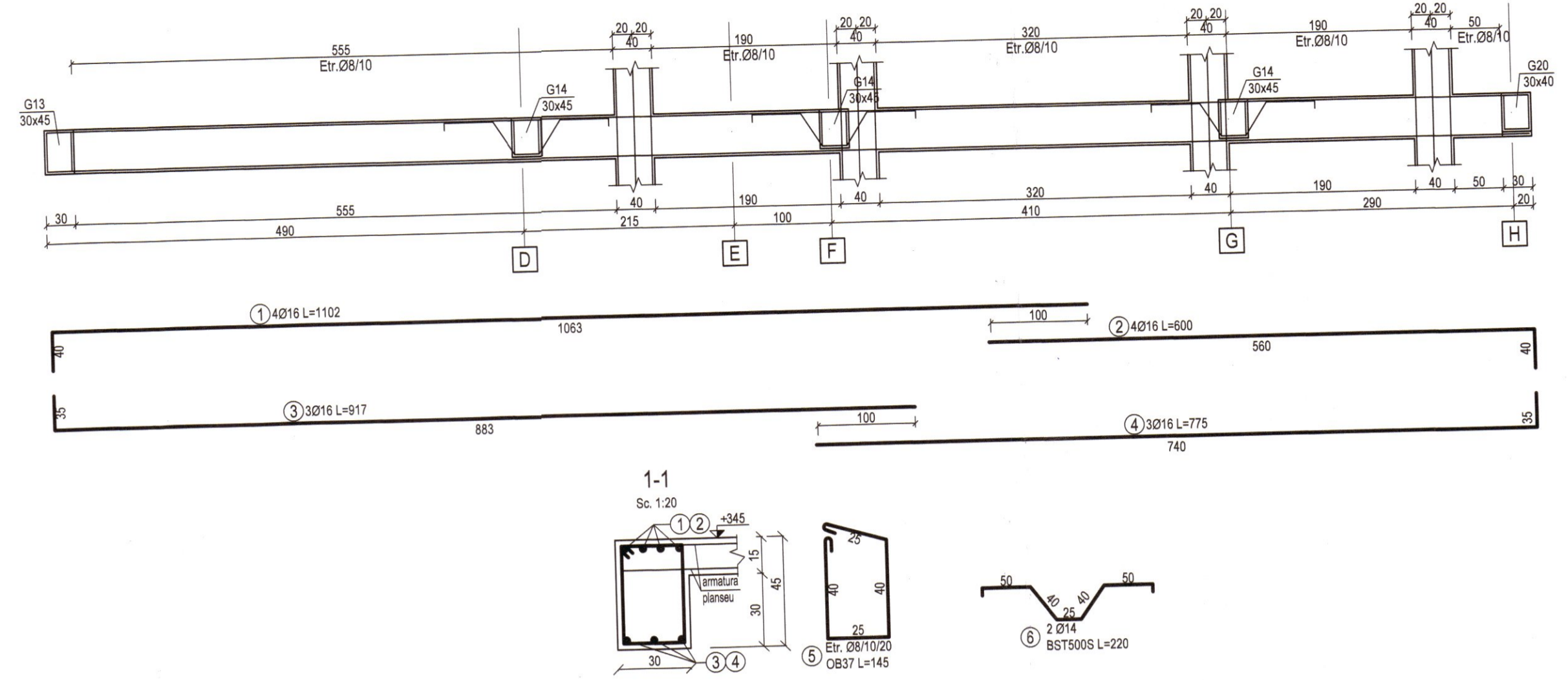

Armare G23 30x45  
1 buc.

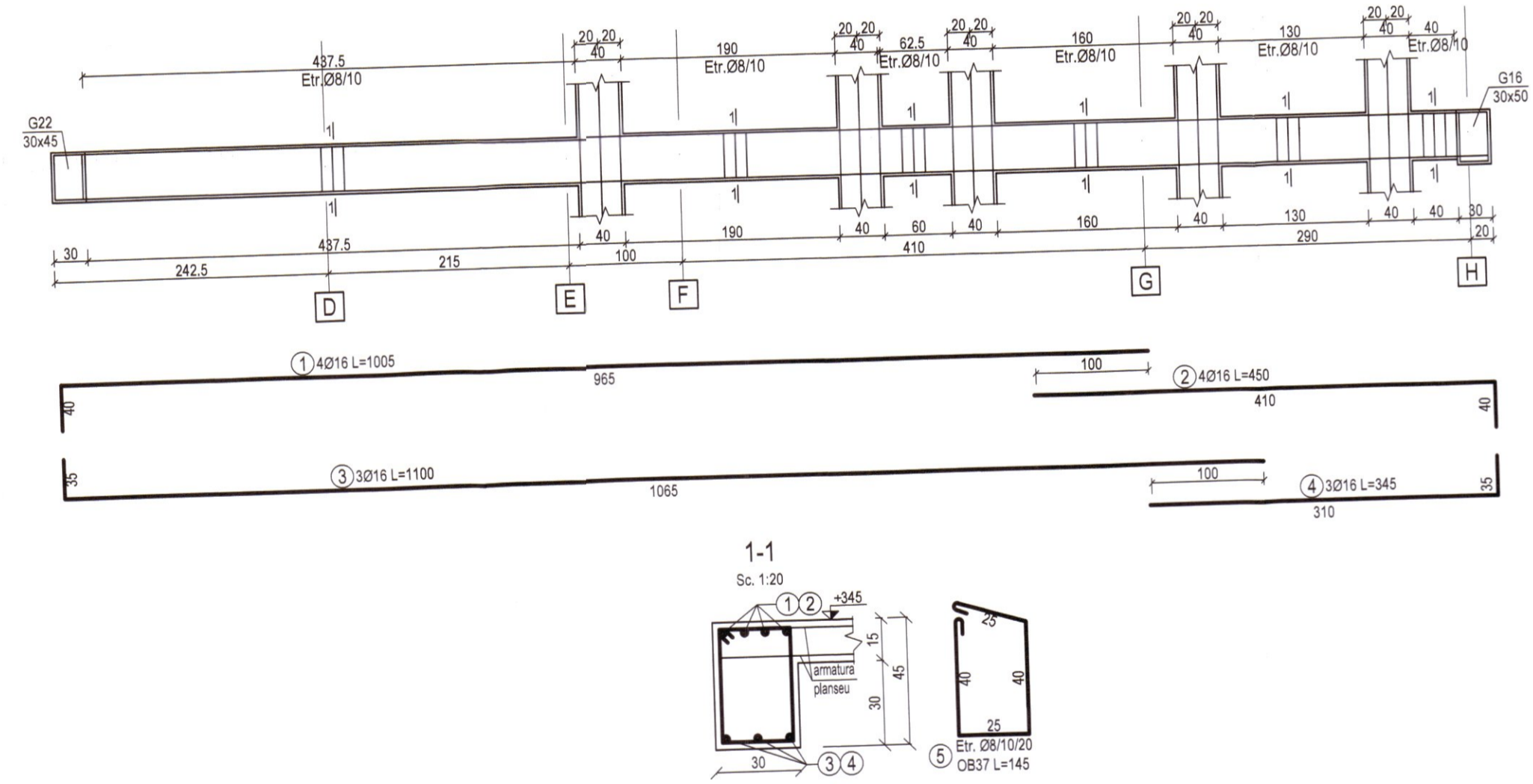

Armare G20 30x40, ax H  
1 buc.

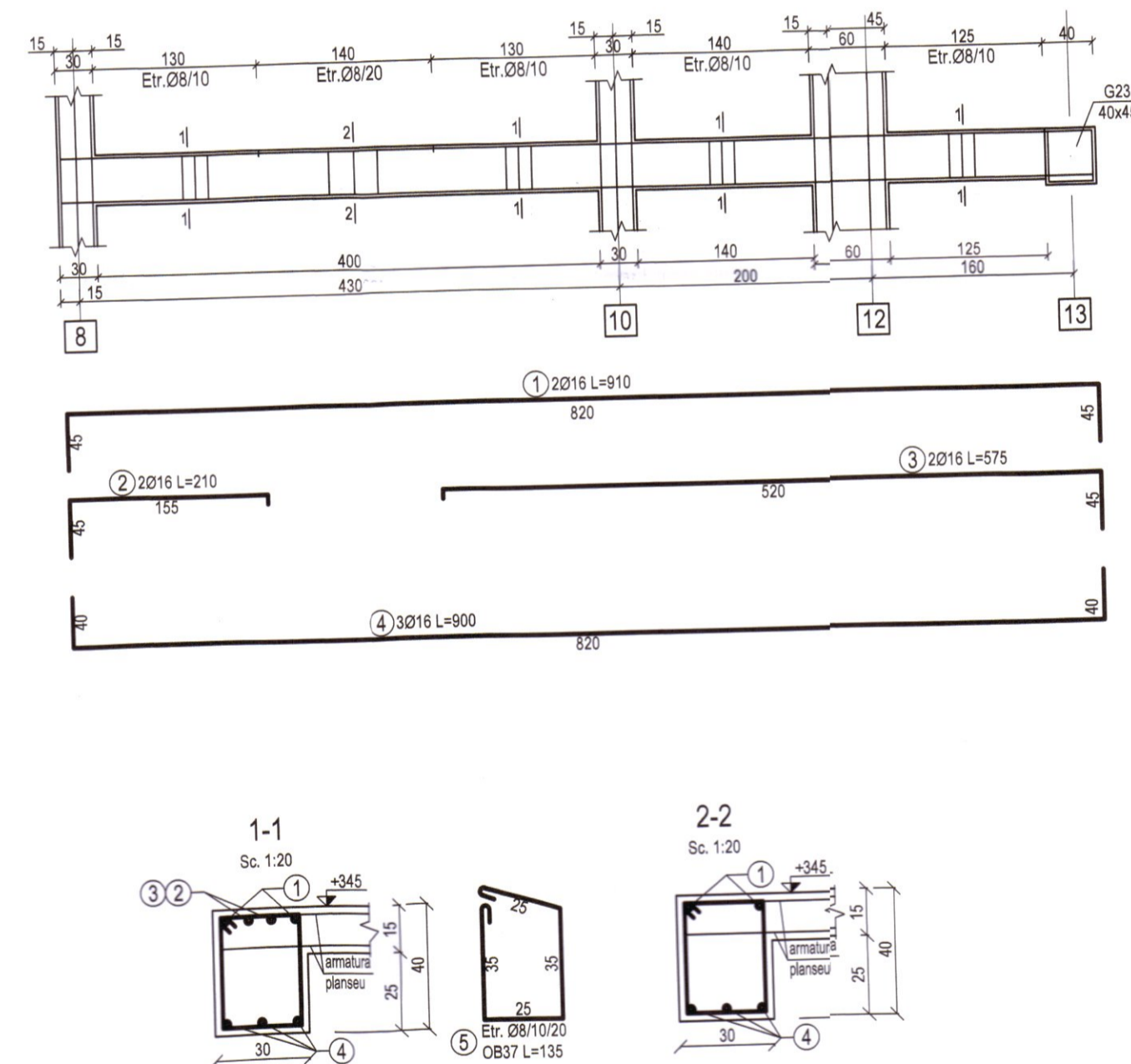

Armare G21 30x35, ax L  
1 buc.

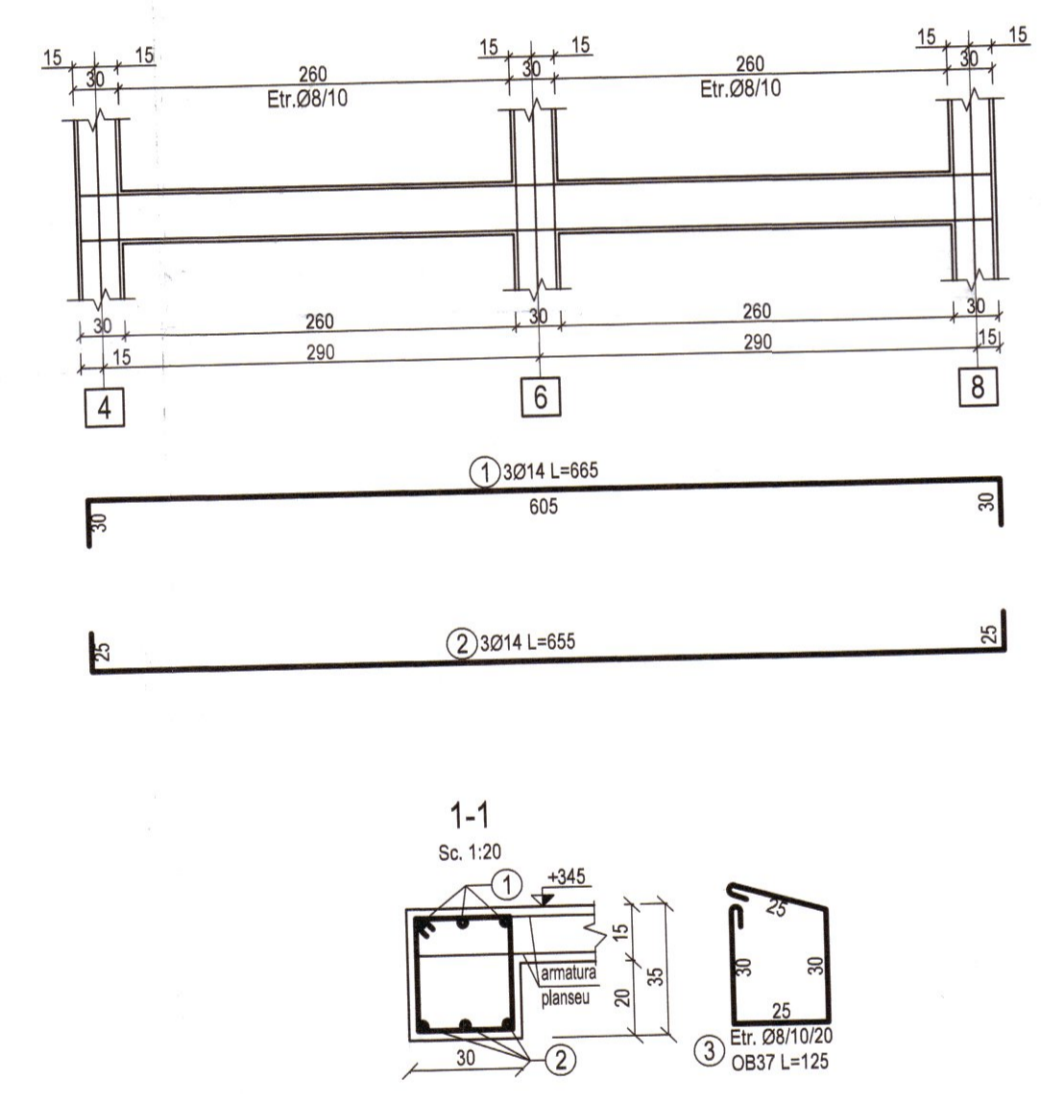

Armare G22 30x45  
1 buc.

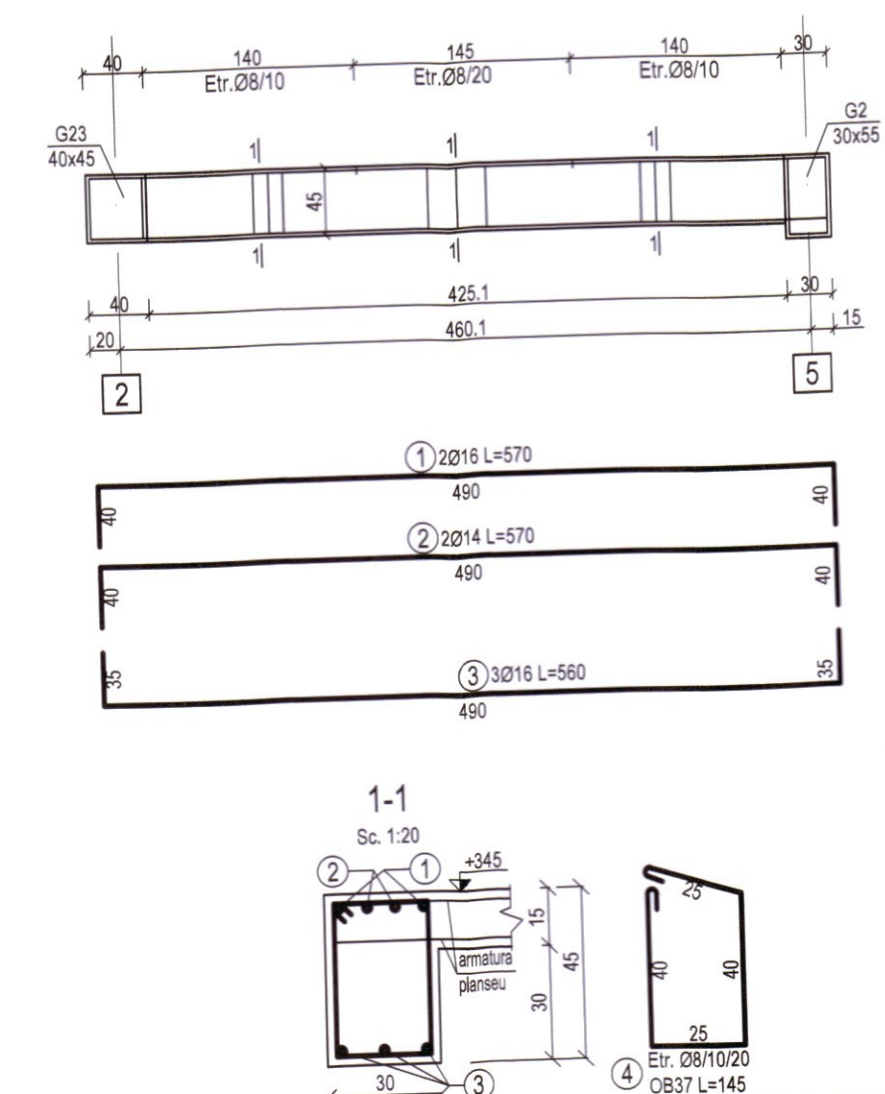

Beton C 8/10 - B 150  
C 16/20 - B 250  
Otel OB 37  
BST500S

Pentru turnare pe timp calduros se va folosi aditiv intarziator de priza+superplastifiant.  
Pentru turnare pe timp friguros (sub 5°C) se va folosi aditiv anti-înghet și accelerator de priza.

VERIFICATOR/Expert: \_\_\_\_\_

EXPERT TEHNIC: \_\_\_\_\_

Beneficiar: s.c. URBAN PLANNING ARCHITECTURE S.R.L. CUI 3984638 2546193.02.019 E-mail: up@urbanplanning.ro

Proiectant: Ing. Jeff FLOIA

Desenat: Ing. Jeff FLOIA

DATA: 01/2025

UP-Architecture

U.A.T. PRUNISOR

Proiect: 70.2

D.T. Plans



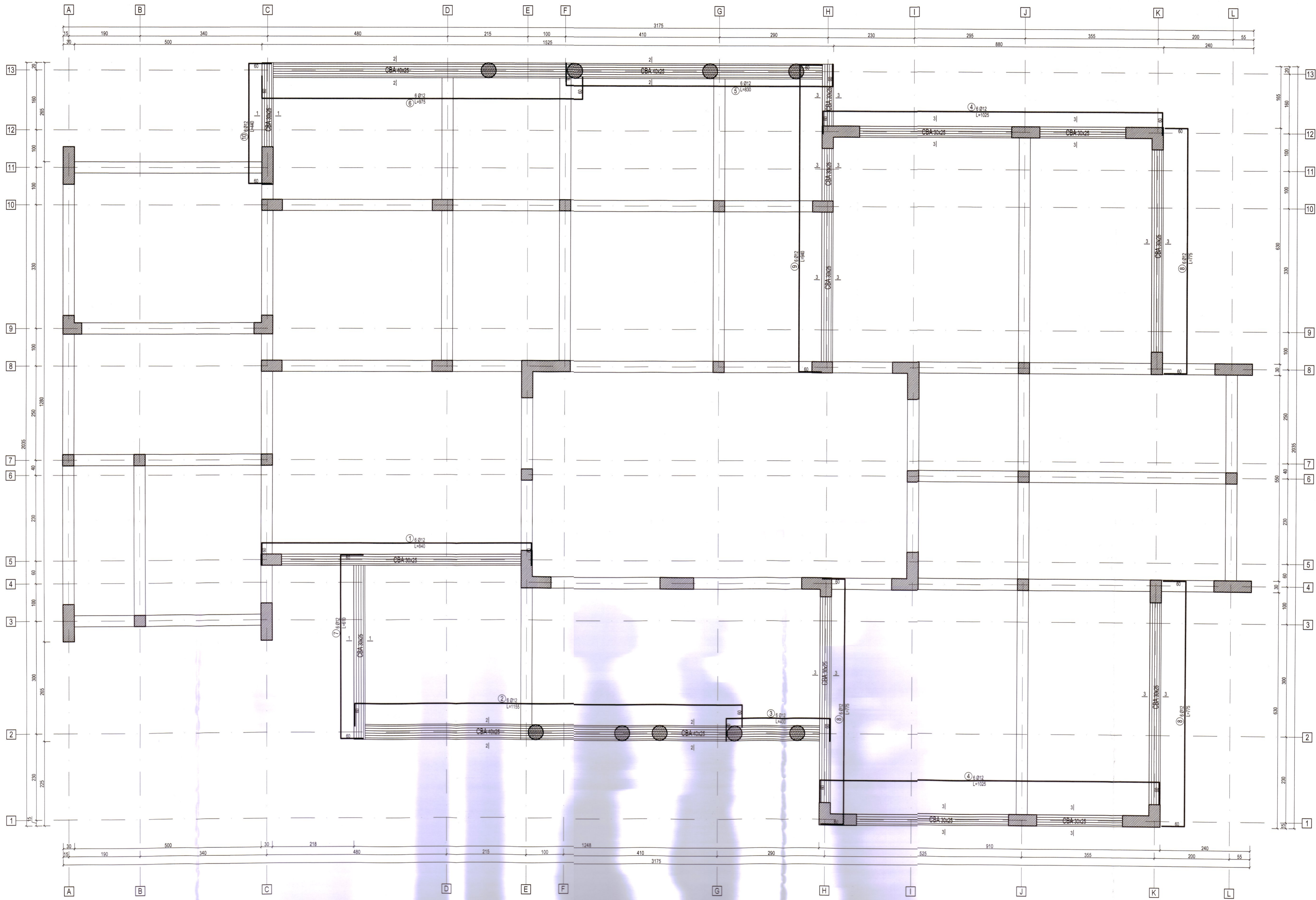

Beton	C 8/10 - B 150
	C 16/20 - B 250
Otel	OB 37
	BST500S

NOTA:  
 CONFORM HG798/1997, CONSTRUCTIA SE INCADREAZA IN CATEGORIA DE IMPORTANTA "C".  
 CONFORM P100-1/2019, ZONA SEISMICA ESTE CARACTERIZATA DE  $a_g = 0.15g$ ,  $T_c = 0.7$  sec.

Pentru turnare pe timp calduros se va folosi aditiv intarziator de priza+superplastifiant.  
 Pentru turnare pe timp friguros (sub 5°C) se va folosi aditiv anti-inghet si accelerator de priza.

NERESPPECTAREA INTOAMAI A PROIECTULUI, DE CATRE BENEFICIAR SAU CONSTRUCTOR, ABSOLVA PROIECTANTUL DE TOATE RASPUINDELE.

Verificator/Expert: \_\_\_\_\_ Nume \_\_\_\_\_ Semnatura \_\_\_\_\_ Cerinta \_\_\_\_\_ Referat \_\_\_\_\_

VERIFICATOR: \_\_\_\_\_ A1, A2, A3 \_\_\_\_\_

EXPERT TEHNIC: \_\_\_\_\_

UP-Architecture s.c. URBAN PLANNING ARCHITECTURE s.r.l.  
 CUI: 39984082 25-481910-2018  
 Email: up-architecture@upar.ro

U.A.T. PRUNISOR

Proiect numar: 70.24/U.P.A.

Sef proiect	ing. Sorin Puiu BARLAN	SEMNATURA	SC:	1/50	OBIECTIV:	Demolare cadavrul existenta CI si	Faza:	D.T.A.C.-P.T.
Proiectat	ing. Jeff PLOIA		DATA:	01/2025	AMPLASAMENT:	nr. cad. 51367, comuna Prunisor, sat Prunisor, jud. Mehedinti	Planşa numar:	R-13
Desenat	ing. Jeff PLOIA		TITLU PAGINA:	PLAN CENTURI ATIC, COTA +405, +445				

SECTIUNEA 1-1

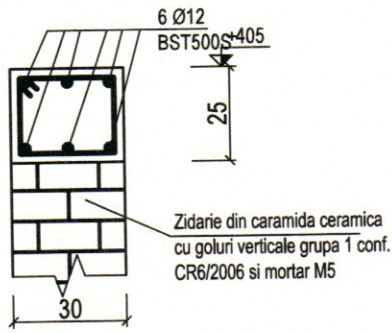

SECTIUNEA 2-2

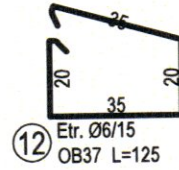
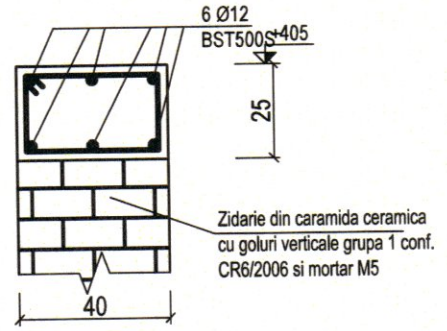

SECTIUNEA 3-3

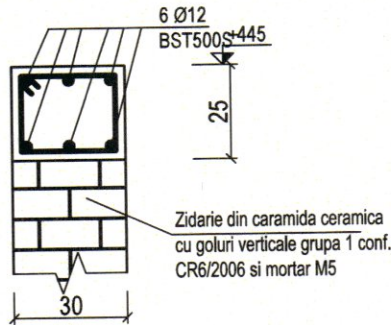

Beton C 8/10 - B 150  
C 16/20 - B 250

Otel OB 37  
BST500S

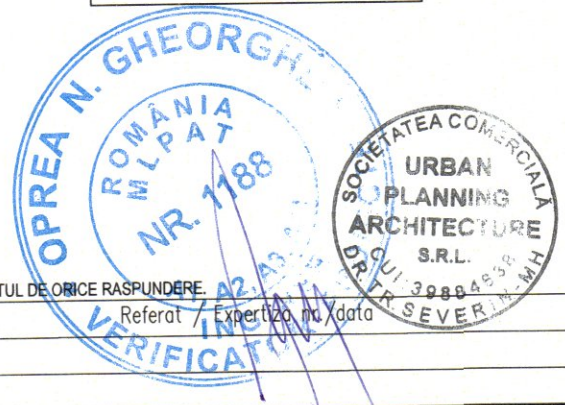

NERESPECTAREA INTOCMAI A PROIECTULUI, DE CATRE BENEFICIAR SAU CONSTRUCTOR, ABSOLVA PROIECTANTUL DE ORICE RASPUNDERE.

Verificatori/Experti:	Nume	Semnatura	Cerinta	Referat / Expertiza nr./data
VERIFICATOR:			A1, A2, A3	
EXPERT TEHNIC:				
<b>UP-Architecture</b> s.c. URBAN PLANNING ARCHITECTURE s.r.l. C.U.I. 39884638 J25/466/18.09.2018 E-mail: - uparchitecture@yahoo.com			BENEFICIAR: <b>U.A.T. PRUNISOR</b>	
NUMELE Sef proiect arh. Sorin Puiu BARLAN		SEMNATURA 		SC: 1/50
Proiectat ing. Jeff PLOIA		DATA: 01/2025		OBIECTIV: Demolare cladire existenta C1 si Construire gradinita doua grupe AMPLASAMENT: nr. cad. 51367, comuna Prunisor, sat Prunisor, jud. Mehedinti
Desenat ing. Jeff PLOIA		TITLU PAGINA: <b>DETALII ARMARE CENTURI</b>		Proiect numar: 70.24/UPA  Faza: D.T.A.C.-P.T.  Plansa numar: R-14

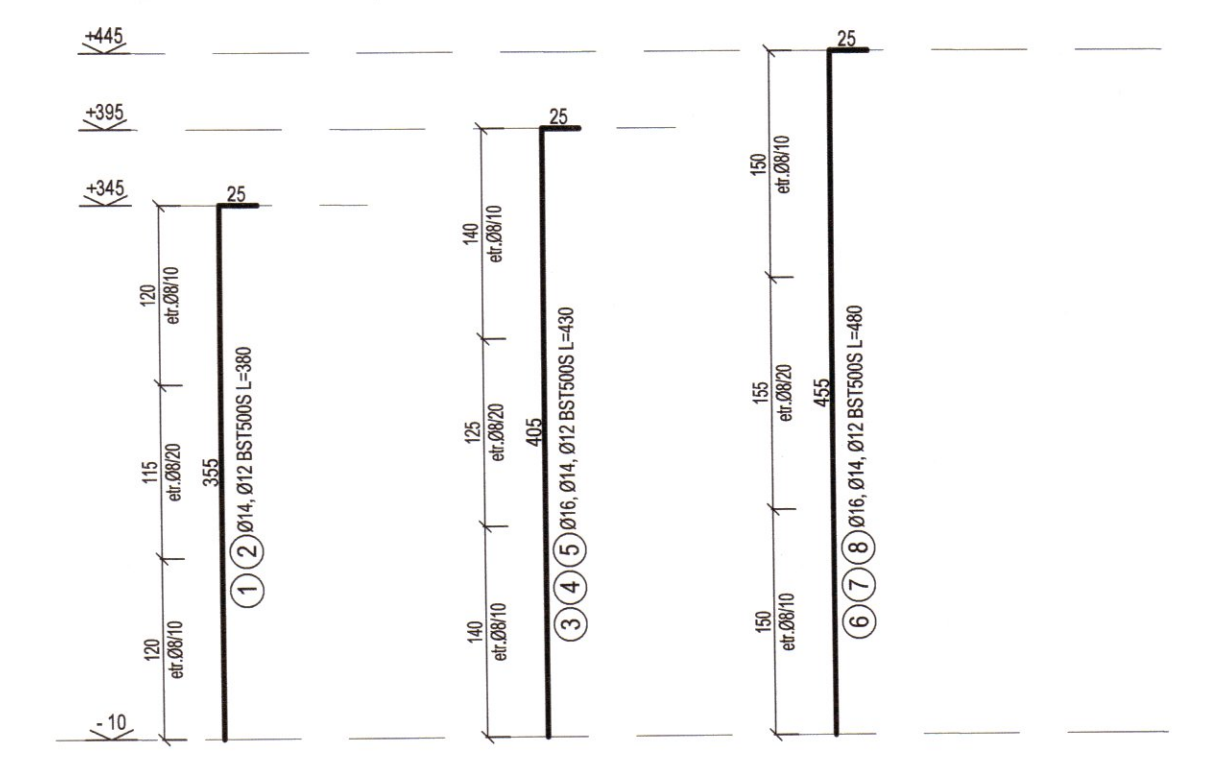
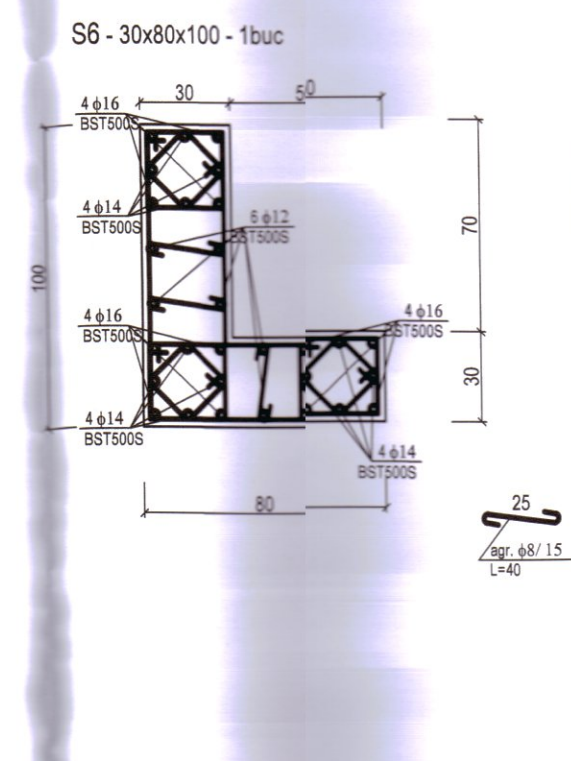
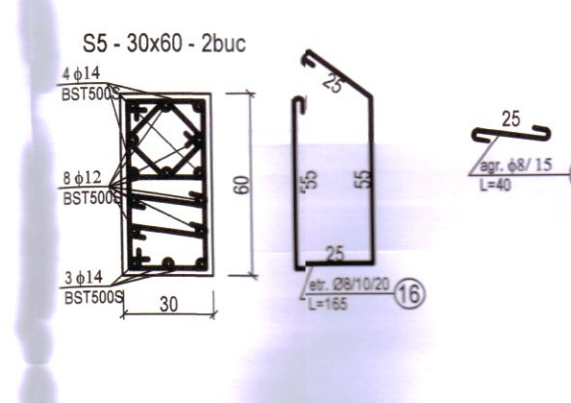
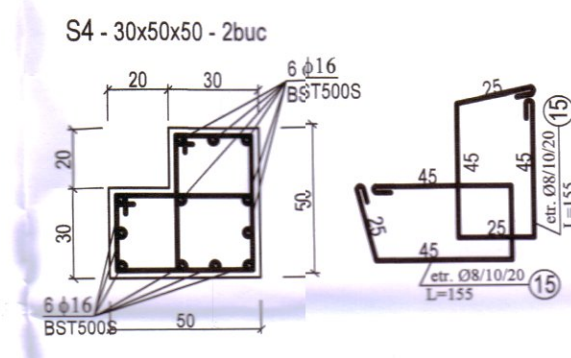
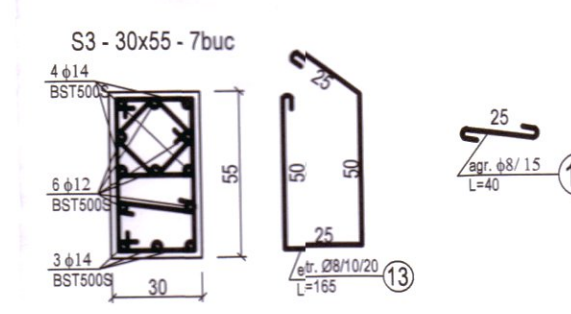
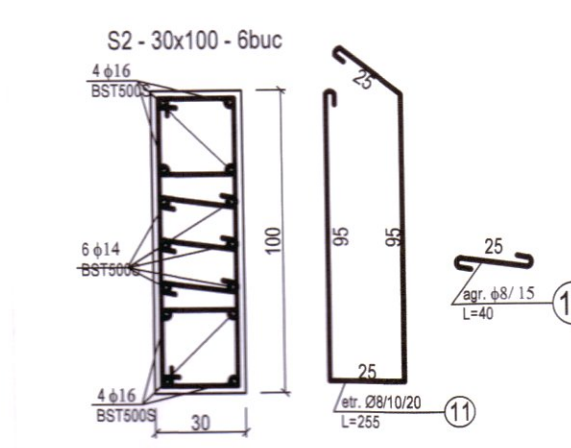
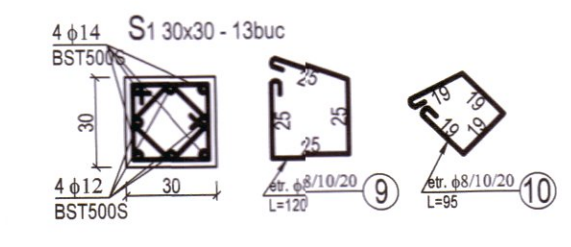
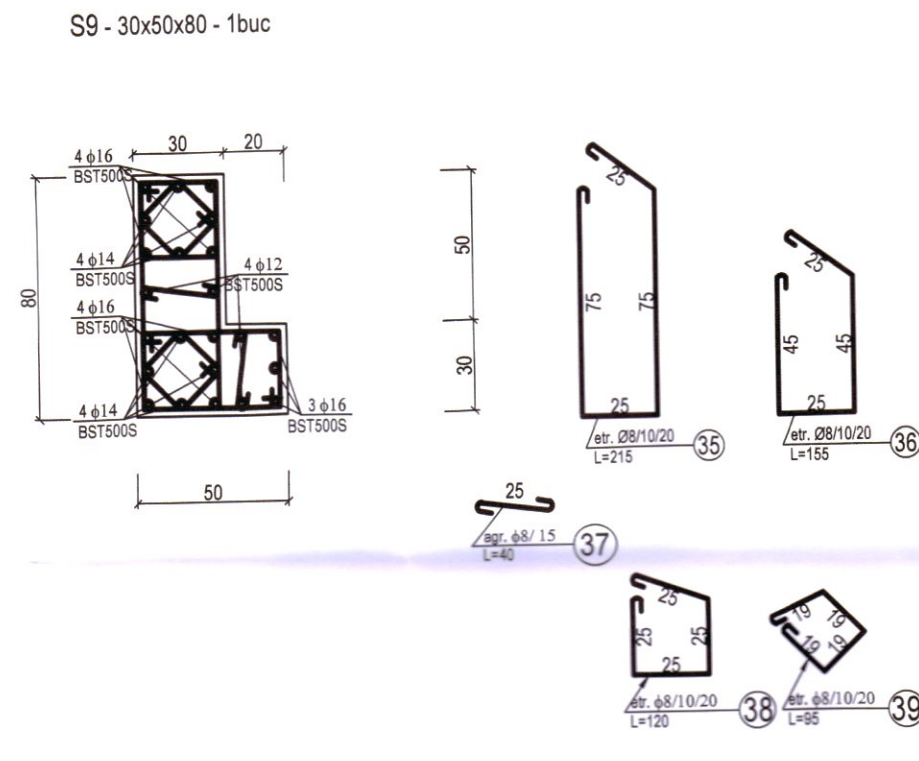
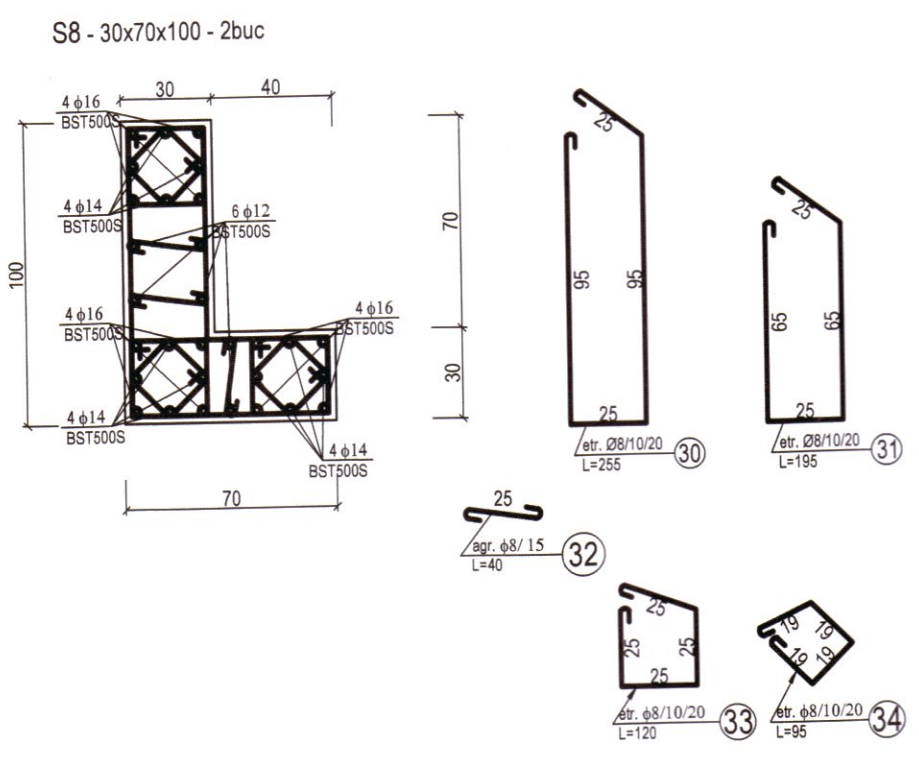
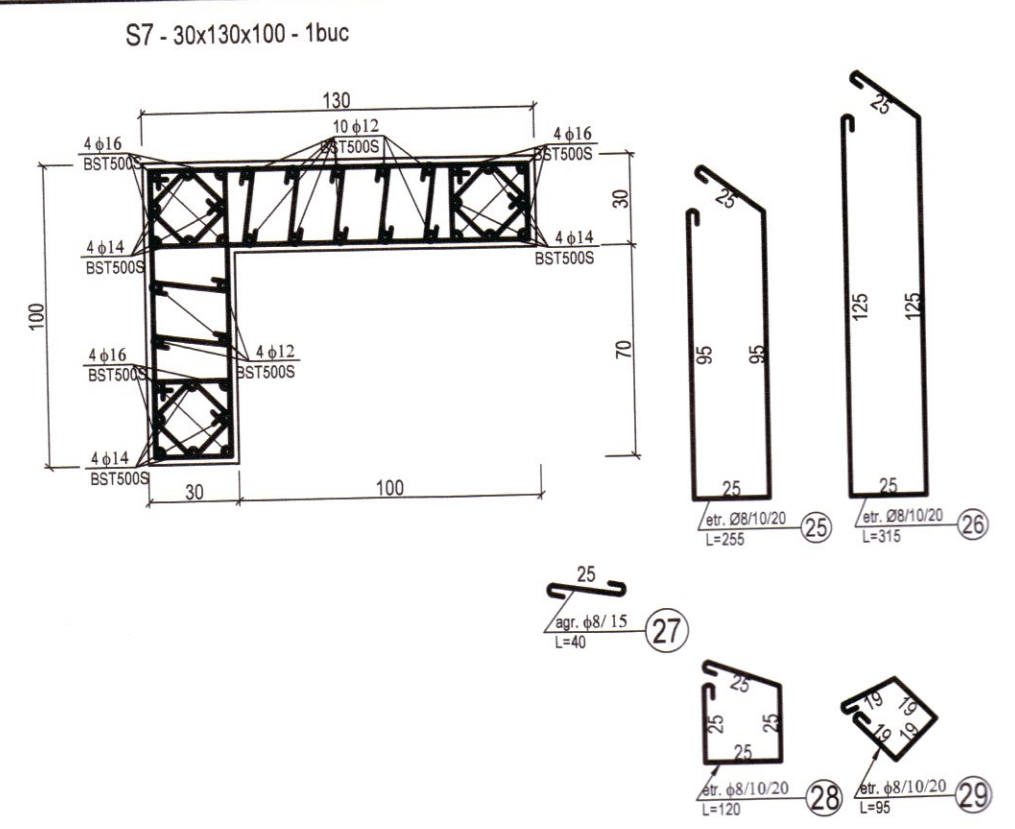

Beton C 8/10 - B 150  
C 16/20 - B 250  
Otel OB 37  
BST500S

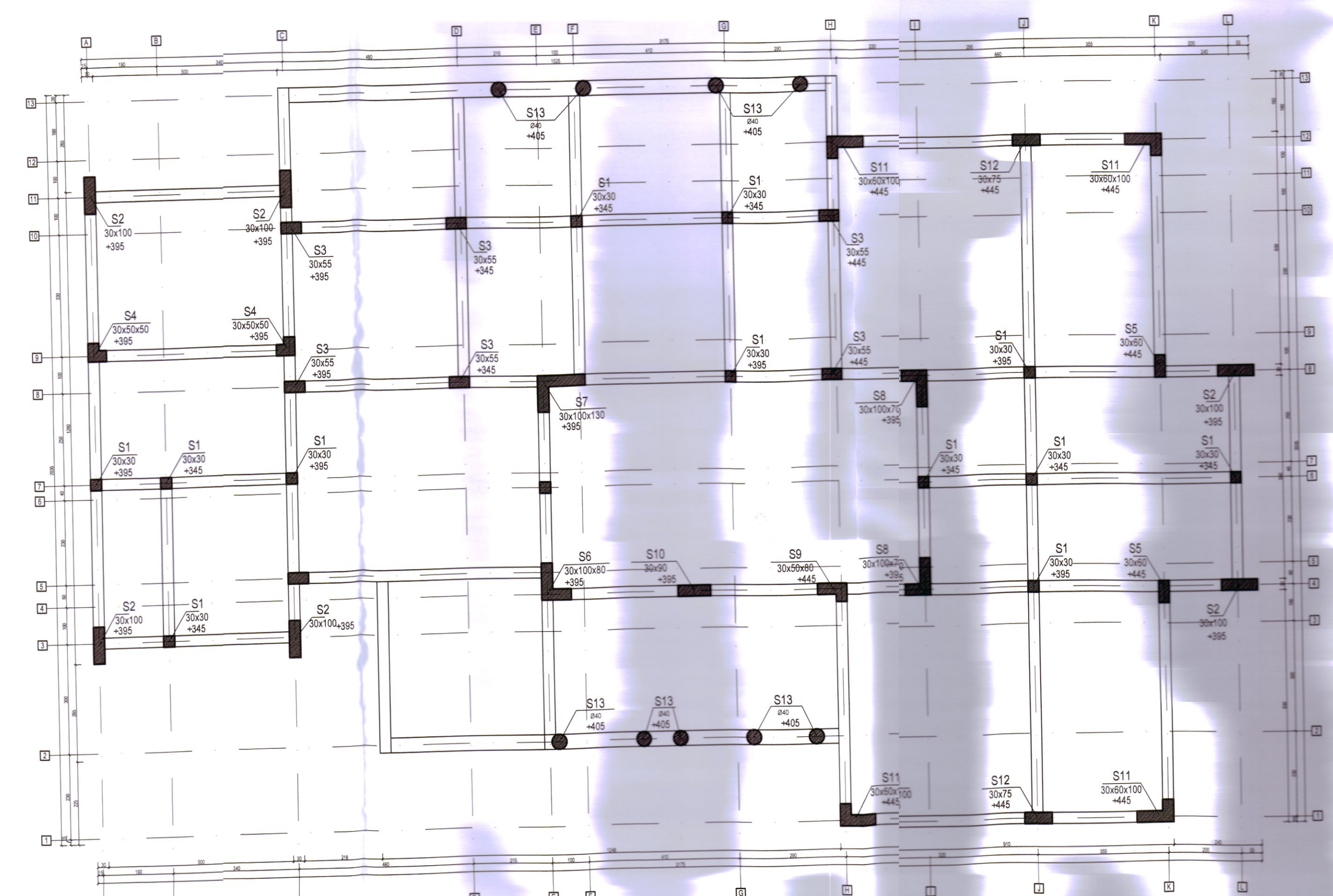
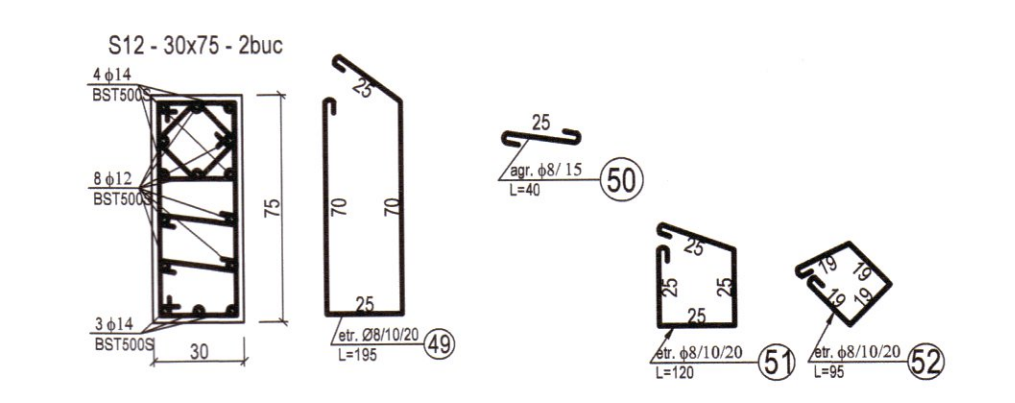
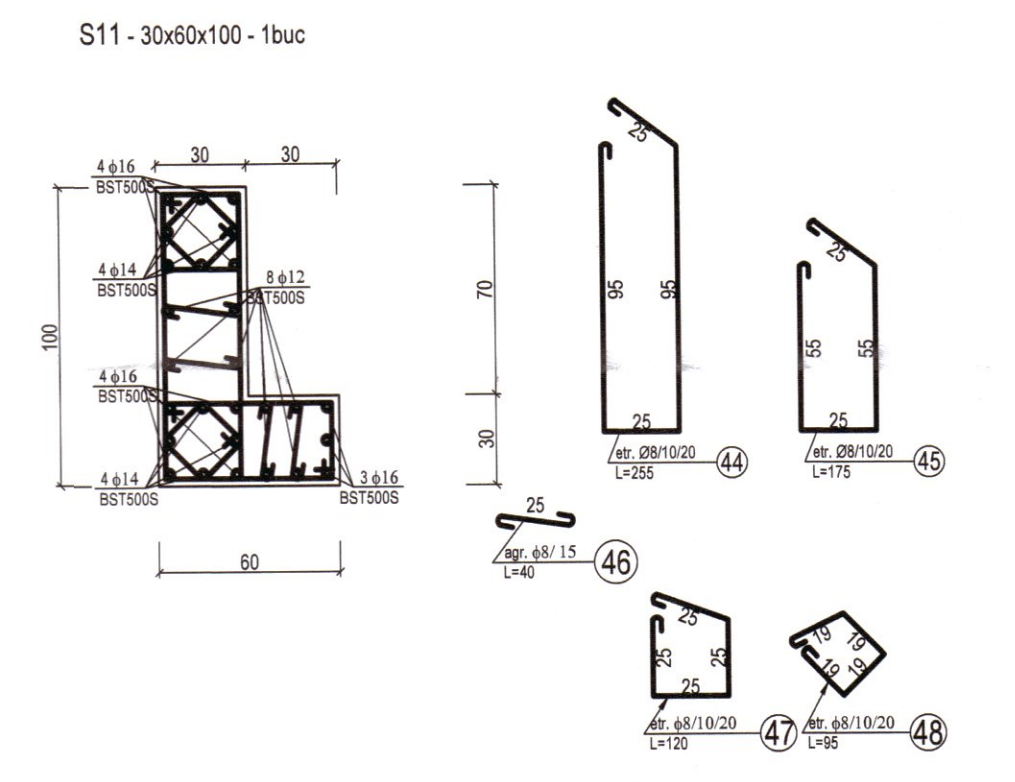
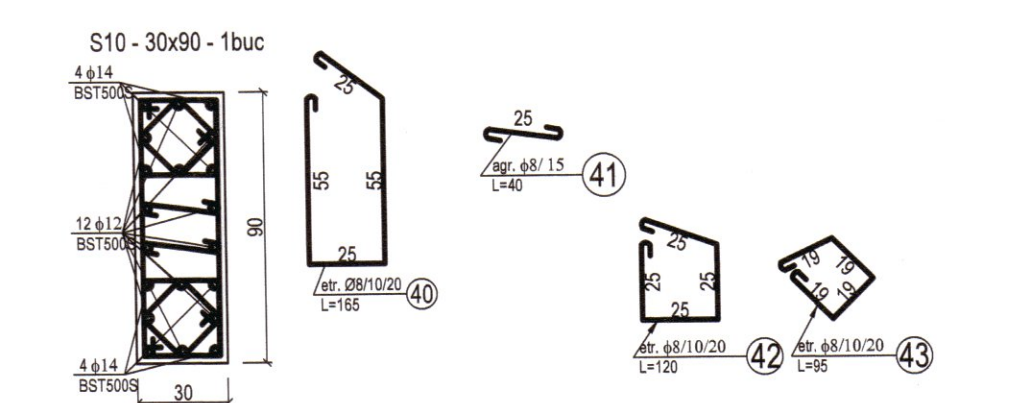

NOTA:  
CONFORM HG766/1997, CONSTRUCTIA SE INCADREAZA IN CATEGORIA DE IMPORTANTANTA "C".  
CONFORM P100-1/2019, ZONA SEISMICA ESTE CARACTERIZATA DE  $a_g = 0.15g$ ,  $T_0 = 0.7$  sec.

Pentru turnare pe timp cald se va folosi aditiv intarziator de priză superplasticizant.  
Pentru turnare pe timp friguros (sub 5°C) se va folosi aditiv anti îngheț și accelerat�or de priză.

VERIFICAREA ÎNTOAMBA A PROIECTULUI, DE CĂTRE BENEFICIAR SAU CONSTRUCTOR, ABSOLVA PROIECTANTUL DE CĂTRE RĂSPUNDEREA SA.

Verificator/Expert:	Nume	Semnatura	Cerinta	Răspunde	Expert/Inginer
VERIFICATOR:			A1, A2, A3		
EXPERT TEHNIC:					

UP-Architecture s.c. URBAN PLANNING ARCHITECTURE s.r.l.  
CUI 3094838 2049018/2018  
E-mail: up-architectur@up-arch.ro

BENEFICIAR: U.A.T. PRUNISOR

PROIECT NUME: DETALIILE ARMAREI STALPI

PROIECT NUMAR: 70.24/UPA

Faza: D.T.A.C.P.

Planşa număr: R-15

DATA: 01/2025

SC: 1/50

OBIECTIV: Detaliile caderii elementelor C1 și C2  
Centru gradina doua grupe

AMPLASAMENT: nr. cad. 51987, comuna Prunisor, sat Prunisor, Jud. Mehedinti

Titlu pagină: DETALIILE ARMAREI STALPI

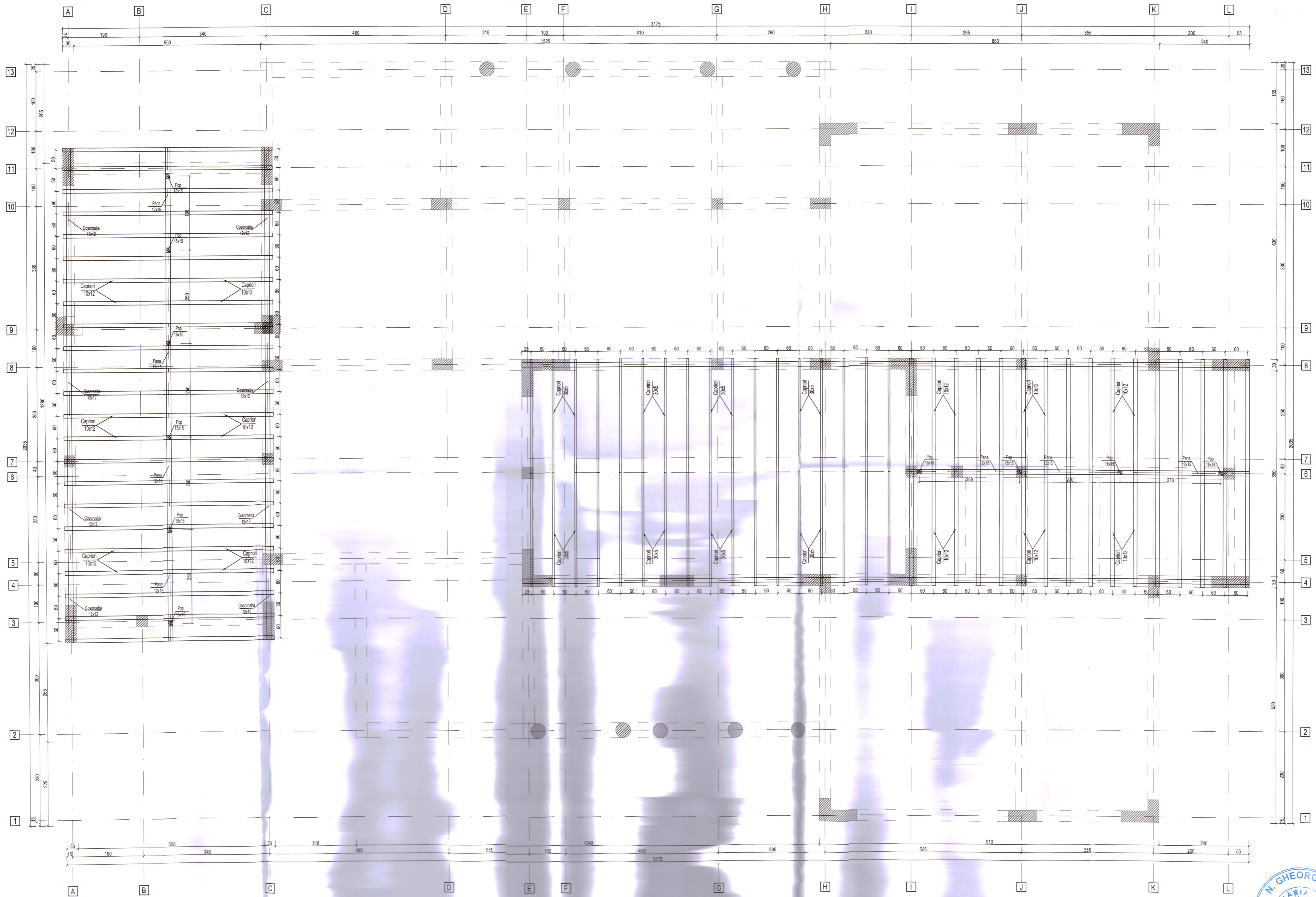

NOTA:  
 CONFORM HG766/1997, CONSTRUCTIA SE INCADREAZA IN CATEGORIA DE IMPORTANTA "C".  
 CONFORM P100-1/2019, ZONA SEISMICA ESTE CARACTERIZATA DE  $a_g = 0.15g$ ,  $T_c = 0.7$  sec.



VERIFICATOR/EXPERT:		Nume		Semnatura		Cerinta		Expertiza	
VERIFICATOR:		AT, AZ							
EXPERT TEHNIC:									
BENEFICIAR:		S.C. URBAN PLANNING ARCHITECTURE S.R.L.		CUI: 3988438		JOS-46918.09.2018		E-mail: <a href="mailto:urbanplanning@uparoc.com">urbanplanning@uparoc.com</a>	
NUMELE		SEMANTURA		SC:		OBIECTIV:		Proiect numar:	
Suf. grad:		ing. Sorin Paul BARLAN		1/50		Denumire cadru element C1 si		70.24 UPA	
Proiectat:		ing. Jeff PLOIA		DATA:		Construire gradina doua grupuri		Faza:	
Desenat:		ing. Jeff PLOIA		01/2025		AMPLASAMENT: nr. cad. 518/1, comuna Prunisor, sat Prunisor, jud. Mehedinti		D.T.A.C.-P.T.	
						TITLU PAGINA:		Planşa numar:	
						PLAN SARPANTA		R-16	

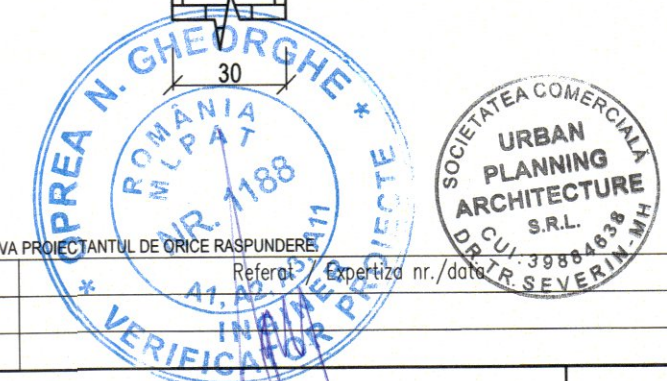
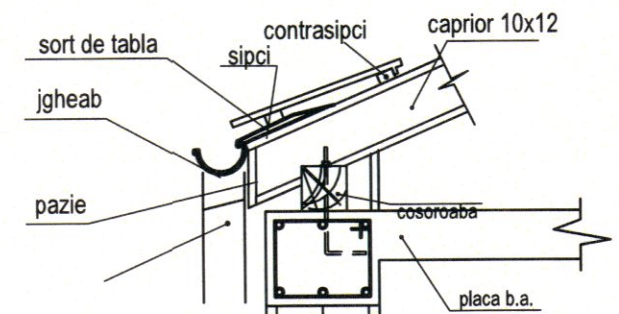
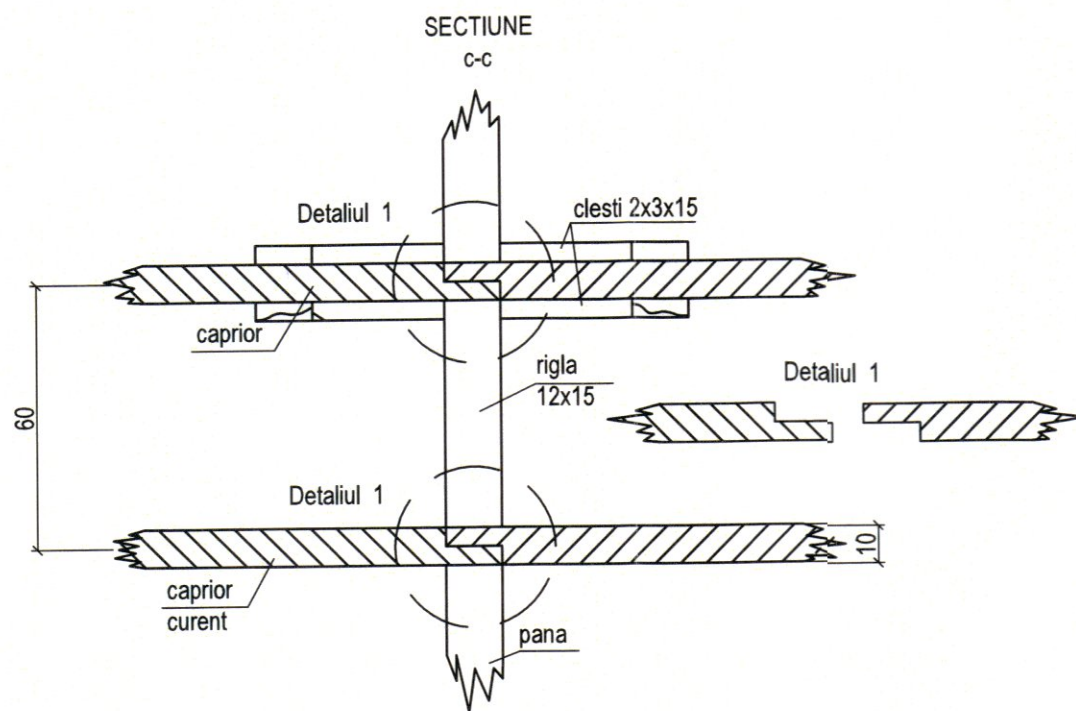
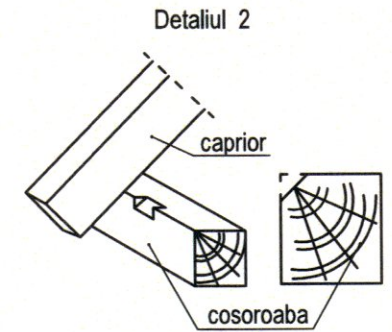
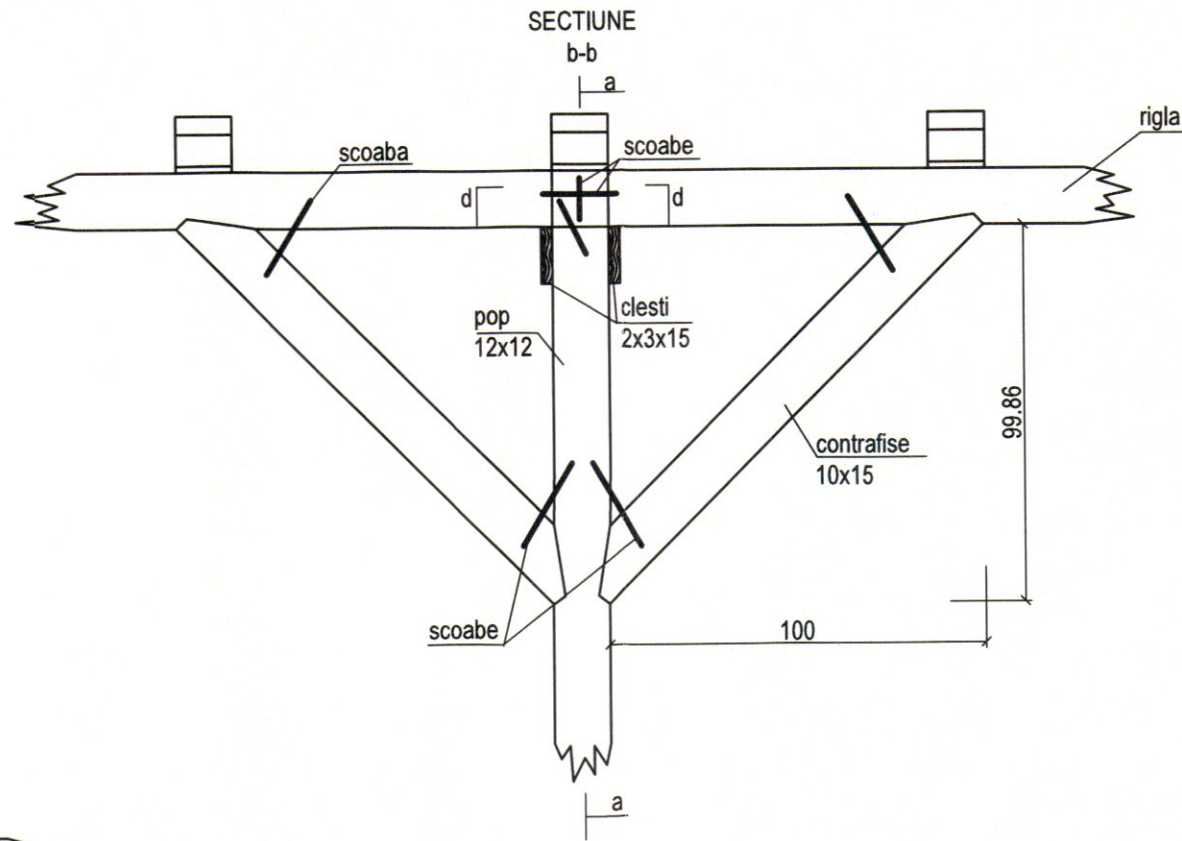
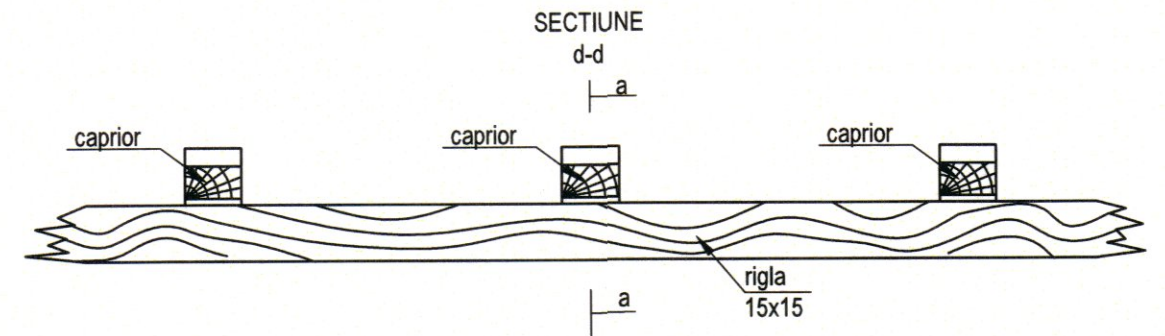
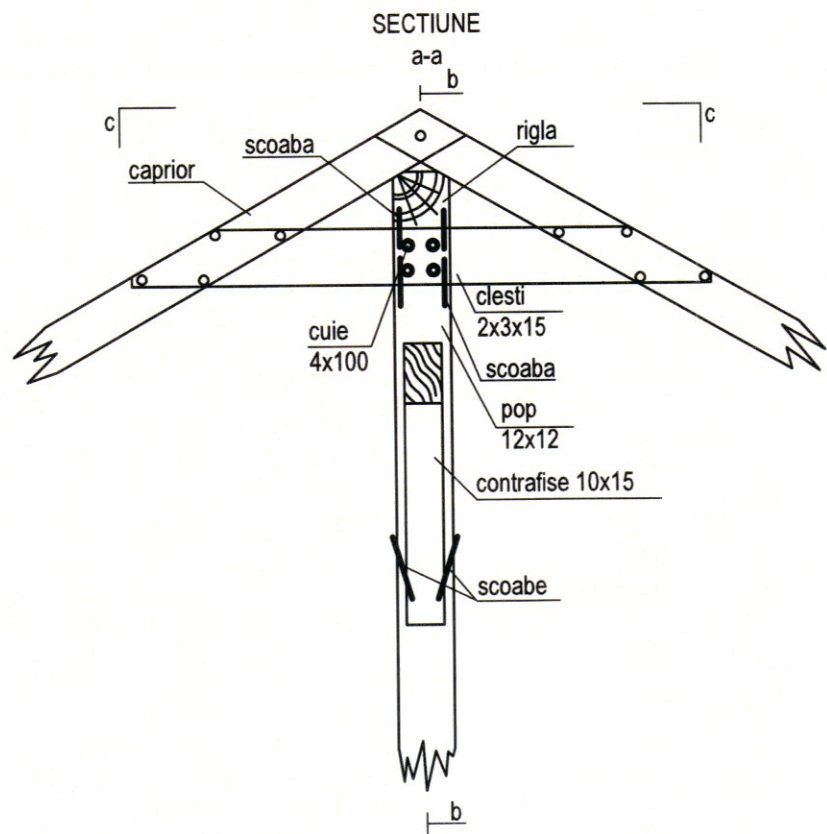

NERESPECTAREA INTOCMAI A PROIECTULUI, DE CATRE BENEFICIAR SAU CONSTRUCTOR, ABSOLVA PROIECTANTUL DE ORICE RASPUNDERE

Verificatori/Experti:	Nume	Semnatura	Cerinta	Refera	Expertiza nr./data
VERIFICATOR:			A1, A2, A3		
EXPERT TEHNIC:					
s.c. URBAN PLANNING ARCHITECTURE s.r.l. <b>UP-Architecture</b> C.U.I. 39884638 J25/466/18.09.2018 E-mail: - uparchitecture@yahoo.com			BENEFICIAR: <b>U.A.T. PRUNISOR</b>		Proiect numar: 70.24/U.P.A.
Sef proiect	arh. Sorin Puiu BARLAN		SC: 1/20	OBIECTIV: Demolare cladire existenta C1 si Construire gradinita doua grupe AMPLASAMENT: nr. cad. 51367, comuna Prunisor, sat Prunisor, jud. Mehedinti	
Proiectat	ing. Jeff PLOIA		DATA: 01/2025	TITLU PAGINA: <b>DETALII SARPANTA</b>	
Desenat	ing. Jeff PLOIA			Faza: D.T.A.C.-P.T. Plansa numar: R-17	

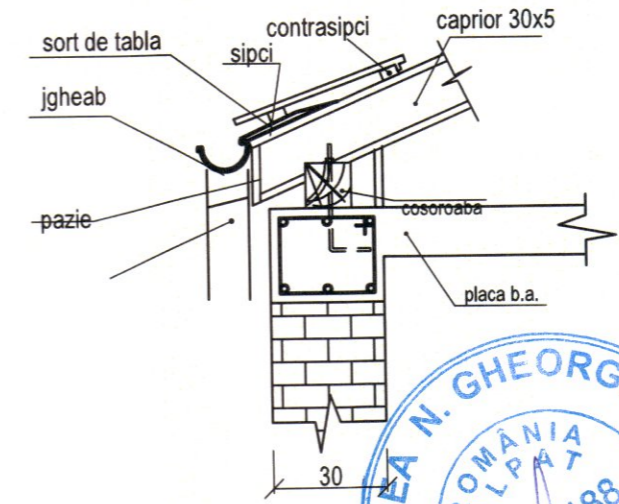
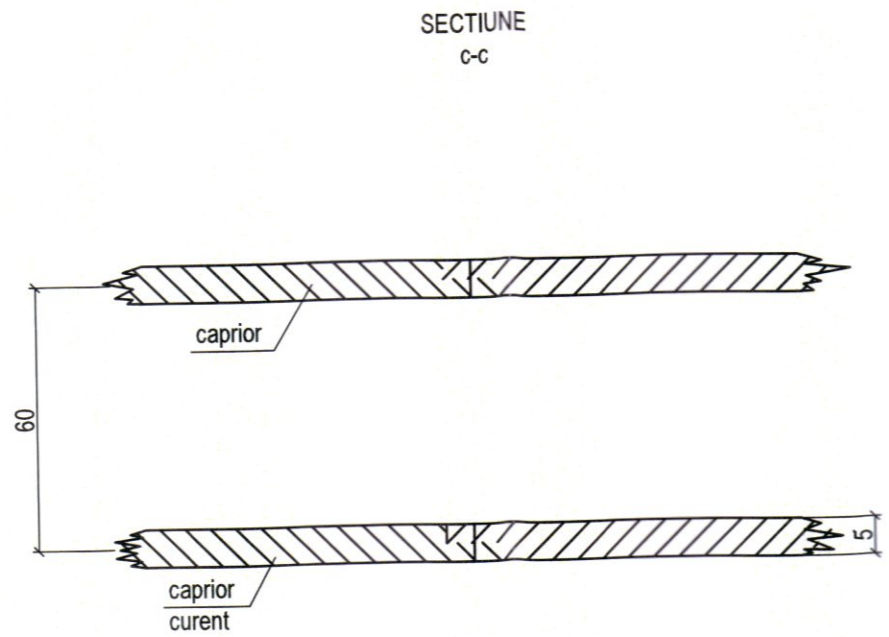
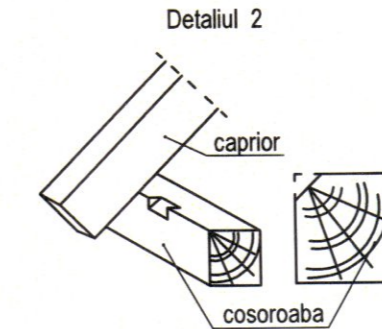
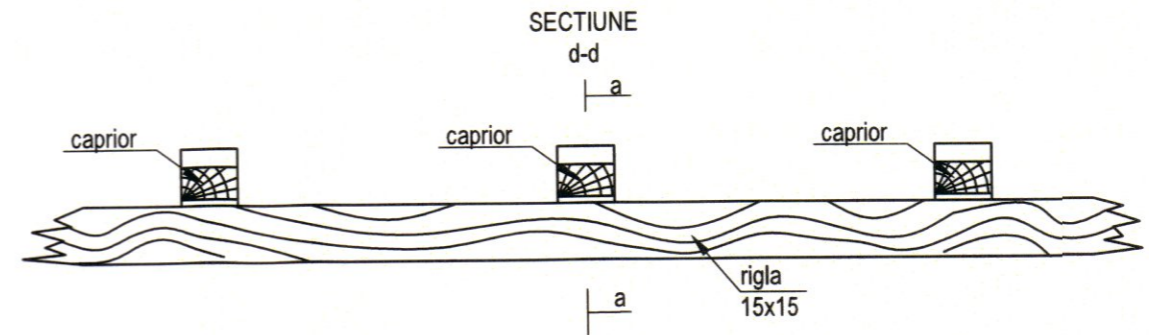
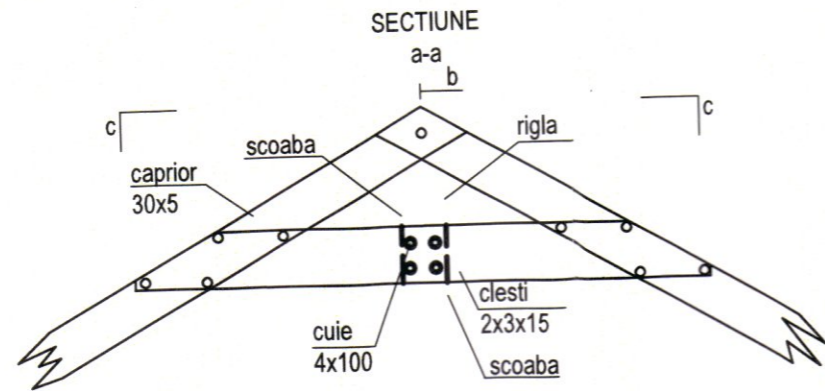

NERESPECTAREA ÎNTOCMAI A PROIECTULUI, DE CĂTRE BENEFICIAR SAU CONSTRUCTOR, ABSOLVA PROIECTANTUL DE ORICE RĂSPUNDERE.

Verificatori/Experti:	Nume	Semnatura	Cerinta	Referat / Expertiza nr./data
VERIFICATOR:			A1, A2, A3	
EXPERT TEHNIC:				

s.c. URBAN PLANNING ARCHITECTURE s.r.l. <b>UP-Architecture</b> C.U.I. 39884638 J25/466/18.09.2018 E-mail: - uparchitecture@yahoo.com			BENEFICIAR: <b>U.A.T. PRUNISOR</b>	Proiect numar: 70.24/UPA
NUMELE arh. Sorin Puiu BARLAN	SEMNATURA 	SC: 1/20	OBIECTIV: Demolare cladire existenta C1 si Construire gradinita doua grupe AMPLASAMENT: nr. cad. 51367, comuna Prunisor, sat Prunisor, jud. Mehedinti	Faza: D.T.A.C.-P.T.
Sel proiect Proiectat Desenat	ing. Jeff PLOIA ing. Jeff PLOIA	DATA: 01/2025	TITLU PAGINA: DETALII SARPANTA	Plansa numar: R-18

